

SmartLock[®]

Slide Retainer and Limit Switch U.S. Patent No. 6,126,429

Operating Instructions

General

The **SMARTLOCK[®]** slide retainer and limit switch provides a slide retainer and SPDT switch in one unique package for use in molding applications to verify slide position and prevent mold damage. Install the plunger and switch assembly into corresponding milled pockets in the slide and mold plate.

In operation, the plunger moves into a recess in the locking plate, providing a detent with 17 to 27 lbs breakaway force. (The breakaway force is adjustable by changing the plunger bore depth.) The switch actuator is located in the bottom of the locking plate recess. The normally open contacts are closed while the plunger is seated in the locking plate. (Captive plunger option includes a 6-32 screw to hold plunger in place.)

Specifications

Rated current is dependent upon operating temperature. A lower operating temperature allows more current safely through the SmartLock cable. See the table below for details.

Rated Current (Resistive) vs. Operating Temperature						
SL-222			SL-291			
Amps	°F	°C	Amps	°F	°C	
5.0	85	29.4	5.0	100	37.7	
4.0	120	49.0	4.5	155	68.3	
3.0	155	68.3	4.0	210	98.8	
2.0	175	79.4	3.5	250	121.1	

Above rated current is resistive. Maximum inductive current is 4A.
 Switching Element ContactsForm C - SPDT
 Maximum Breakaway Force27 lbs (12.1 kg)
 Minimum Breakaway Force.....17 lbs (7.7 kg)
 (user adjustable, see pages 2 and 3)
 Utilization Categories.....AC-12, DC-12
 Rated Insulation Voltage..... $U_i = 250V$
 Rated Impulse Withstand Voltage $U_{imp} = 2.5kV$
 Pollution.....Pollution Degree 3
 Relative Humidity should not exceed 50% at max temp +40°C.
 Higher relative humidity is acceptable at lower temperatures e.g.
 90% at +20°C
 Maximum Rated Altitude3,000 m

Operating and Storage/Transport Temperatures:
 SL-222 series-53.9°C to +79.4°C
 SL-291 series-53.9°C to +121°C

bunger & brown
engineering, inc.
 4500 E 142nd Street
 Grandview, MO 64030
 Tel. (816) 878-6675
 www.smartflow-usa.com

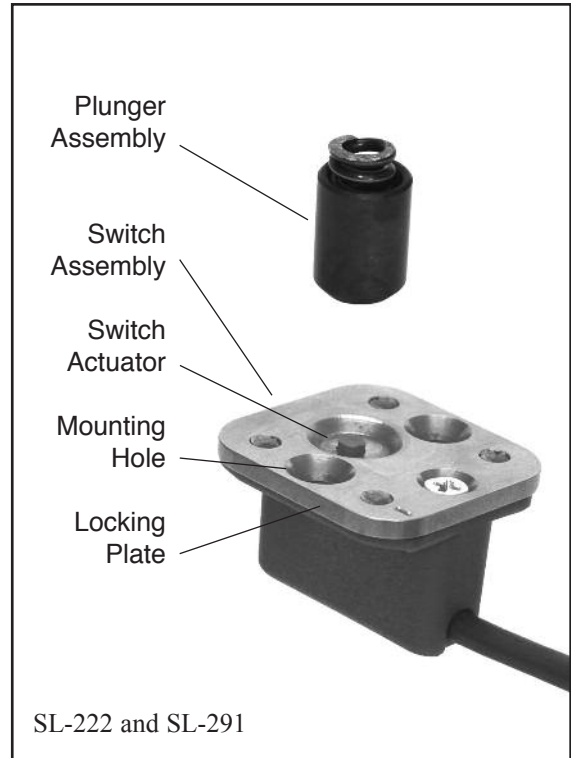

Materials

Body.....Fiberglass-reinforced nylon
 Locking Plate.....Hardened Steel
 Plunger and Spring.....Hardened Steel
 Wire Leads......22ga stranded,
 3-conductor, shielded cable,
 6ft (1.8m) long, ends stripped and tinned

Parts Included

Qty	Description
1	Switch assembly
1	Plunger assembly (spring included)
2	6-32 flat head switch mounting screws
2	10-24 wire clamp mounting screws
2	wire clamps
1	instruction sheet
(1)	6-32 flat head capture screw only with captive plunger option)

Installation

1. Select the correct break-away force and plunger bore depth for your application. Bore depth figures are based on .001" (.025 mm) clearance under the slide. See figure 1.
2. Machine plunger and switch assembly pockets:
 - figure 2a (11mm plunger dia.) or
 - figure 2b (14mm plunger dia.)
 - figure 3 (all switches)
 Pockets must be machined so that switch components match per figure 4 with switch actuated and slide locked. De-burr any surfaces which may come in contact with the switch wire to prevent wire damage.
3. Install the switch assembly into the mold plate. Do not nick the wire insulation. Shorted wiring will cause switch malfunction. Switch wiring is configured as shown in figure 5.
4. Apply grease to the bore for the plunger assembly. Install the plunger and spring into the slide. Install the capture screw (if present). Ensure the screw head is below flush with the slide surface. Thread locking compound is recommended.
5. Install the slide into the mold to test component location. Move the slide manually so the plunger moves into the recessed area of the locking plate. It should take some force (depending on your plunger bore depth) to move the slide out of the locked position.

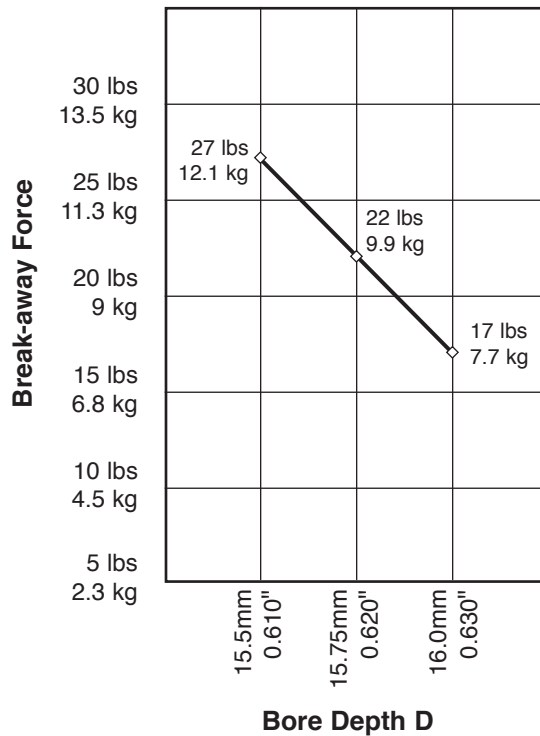

Break-away Force vs. Bore Depth [.001" (.025 mm) clearance under slide] figure 1

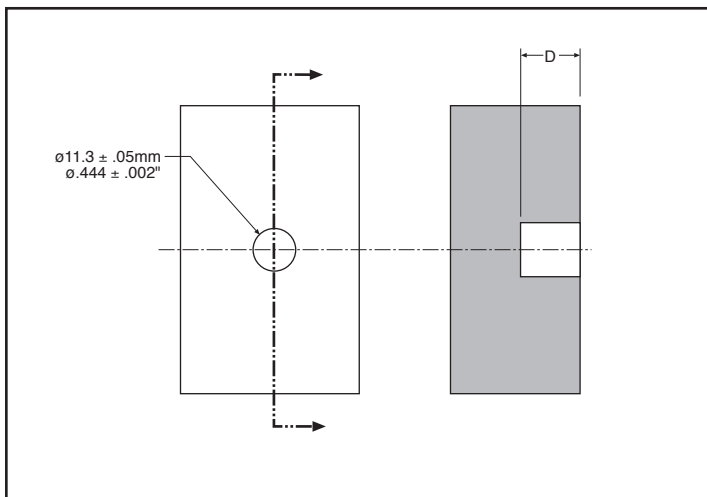

Standard Plunger (11mm dia.) Pocket Dimensions
 SL-222-S-S or SL-291-S-S
 figure 2a

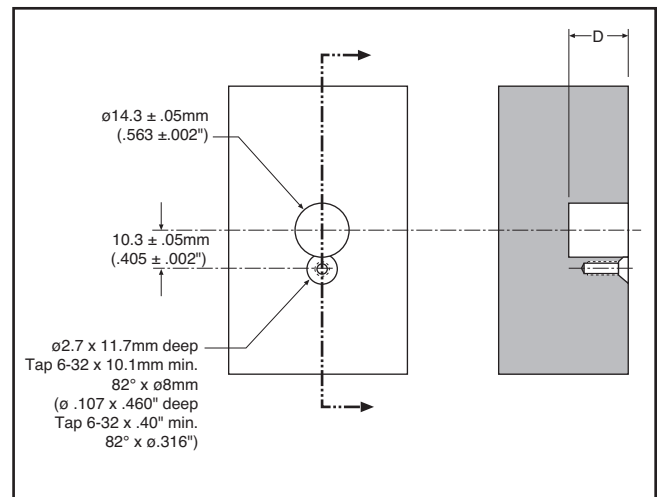

Captive Plunger (14mm dia.) Pocket Dimensions
 SL-222-S-C or SL-291-S-C
 figure 2b

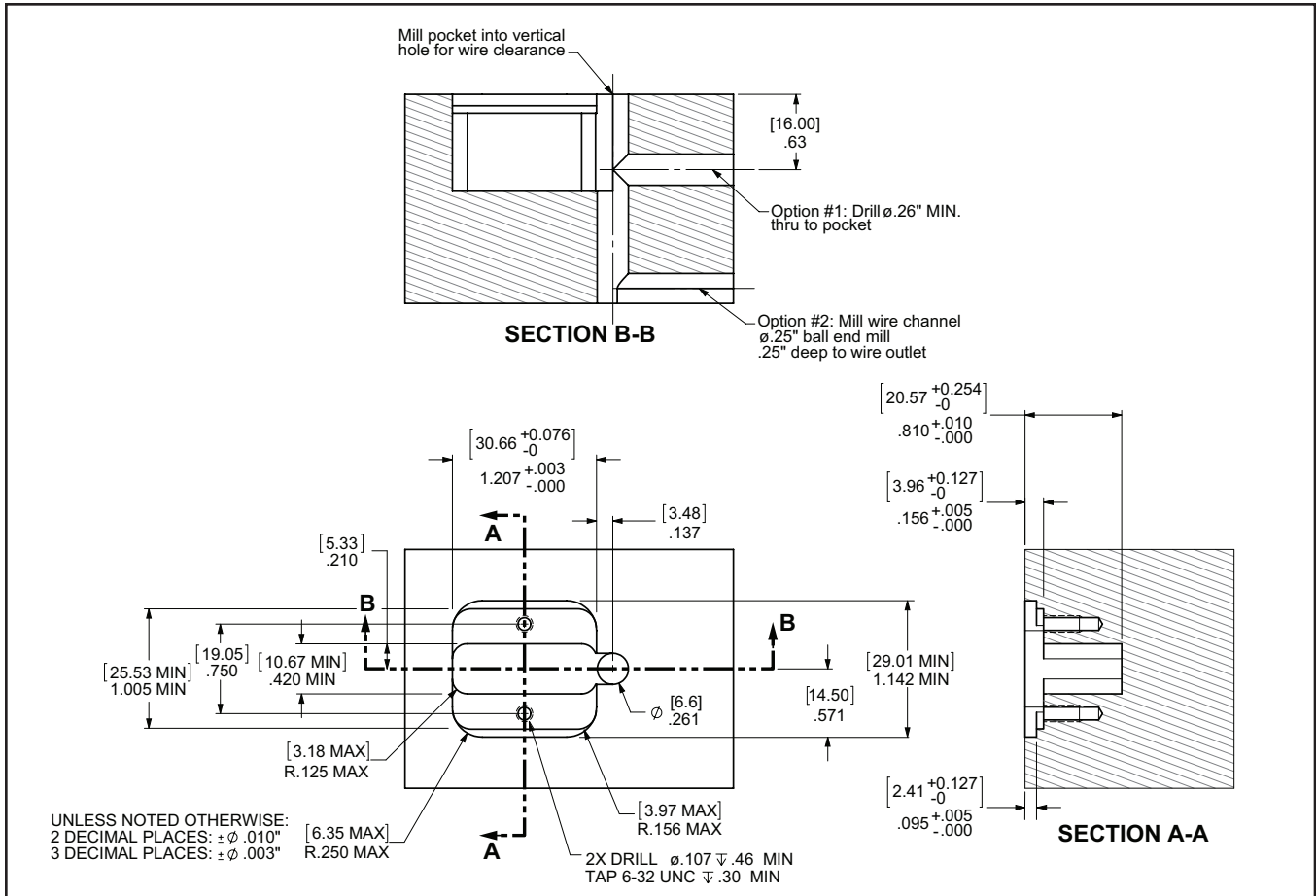

Switch Assembly Pocket Dimensions

figure 3

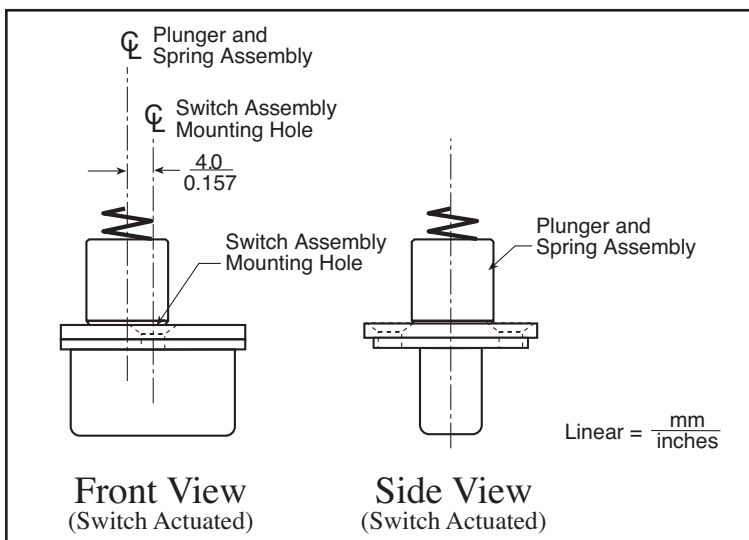

Plunger and Switch Interface Dimensions

figure 4

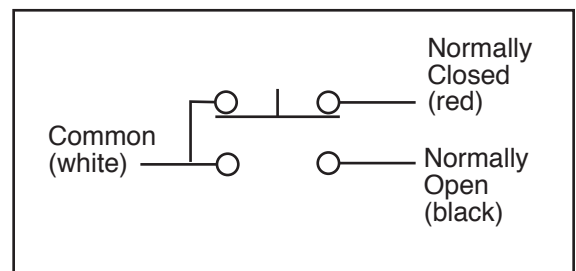

Switch Diagram

figure 5

Troubleshooting

Symptom

Plunger is seated in recess, but switch does not actuate.

Corrective Action

- Check operating point of switch. Actuation point should be .020" to .025" (max.) above the bottom of the plunger recess (see figure 6).

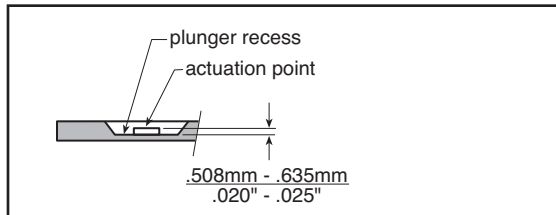

Switch Operating Point

figure 6

- Check wires with ohmmeter. (In normal condition, red and white contacts should have zero resistance, white and black contacts should have infinite resistance.) If switch is defective, contact the factory.

Plunger does not seat in recess.

- Check installation dimensions.

Slide does not lock or move out of locked position with the correct amount of force.

- Check plunger bore dimensions.

If corrective action fails to correct the problem, please contact the factory.

Limited Warranty

Seller warrants that this product supplied will conform to the description herein stated and that the product will be of standard quality. This is the sole warranty made by Seller with respect to this product. Seller expressly disclaims any other express or implied warranties, including, but not limited to, the implied warranty of merchantability and the implied warranty of fitness for a particular purpose.

Seller shall not be liable for any cost or damages, whether direct, incidental or consequential, including, but not limited to, any injury, loss or damage resulting from the use of this product, regardless of whether any claim for such cost or damages is based on warranty, contract, negligence, tort or strict liability. The sole liability of Seller is limited to repairing or replacing this product.

This warranty shall not apply to any products that have been repaired or altered by anyone other than Seller. The warranty shall not apply to any products subject to misuse due to common negligence or accident, nor to any products manufactured by Seller which are not installed or operated in accordance with the printed instructions of Seller or which have been operated beyond the rated capacity of the goods. Seller states that the product's useful safe life is 5 years. Actual life may vary widely depending on operating environment such as temperature, pressure, and chemical exposure.