

HOT SPRUE BUSHINGS

Decimal Equivalents & Tap Drills Sizes.....	L37
Hot Sprue Bushing Benefits PCS - Mini & Standard.....	L3
Hot Sprue Bushing Selection Guide.....	L4
Hot Sprue Bushing Spare Parts - Mini FSB & FSBH.....	L16
Hot Sprue Bushing Spare Parts - PCS Standard HSB	L17
Hot Sprue Bushings - PCS Mini FSB.....	L7
Hot Sprue Bushings - PCS Mini FSBH.....	L8
Hot Sprue Bushings - PCS Mini Introduction.....	L6
Hot Sprue Bushings - PCS Standard HSB.....	L12
Hot Sprue Bushings 200 Series Standard.....	L18
Hot Sprue Bushings 500 Series Standard.....	L21
Hot Sprue Bushings 800 Series Standard.....	L24
Injection Molding Trouble Shooting Guide.....	L35
Resin Material Processing Guide.....	L36
Wattage/Amperage/Resistance Chart.....	L38

HOT SPRUE BUSHINGS

PCS Company Hot Sprue Bushings are ideal for many different applications with options for part weights up to 3000 grams. When incorporated into the mold design, Hot Sprue Bushings reduce waste, minimize cycle time and can be used with both commodity and engineering grade resins.



PCS HOT SPRUE BUSHINGS

PCS Mini Hot Sprue Bushings

- Designed to fit standard industry tooling inserts including FITS®, MUD®, RTI® and others
- Compact design for small part and/or runner applications in A or B series mold bases
- Reduces material waste
- Helps minimize cycle time
- Available in standard inch dimensions
- With and without head heater (one or two zones of control)
- Capability to process commodity and engineered resins filled or unfilled
- Heaters rated at 240 VAC
- J type thermocouple
- In stock at PCS
- Various tip configurations
- Locating Rings in stock at PCS
- Designed for total shot weights up to 70 grams
- Refer to Hot Sprue Selection or call PCS Company
- 2D & 3D CAD data online at www.pcs-company.com



PCS Standard Hot Sprue Bushings

- Replaces the standard cold sprue bushing
- Reduces material waste
- Helps minimize cycle time
- Available in standard inch and metric dimensions
- Standard and High Performance hot sprue bushing assemblies available
- Capability to process commodity and engineered resins filled or unfilled
- Heaters rated at 240 VAC
- J type thermocouple
- Spare thermocouple for the nozzle body
- In stock at PCS
- Various tip configurations
- Locating Rings in stock at PCS
- Locating rings for the 800 and 1000 series hot sprue bushings designed per application
- Designed for total shot weights up to 3000 grams
- 2D & 3D CAD data online at www.pcs-company.com



HOT SPRUE BUSHING SELECTION GUIDE

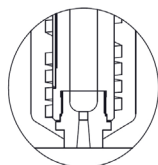

Sprue Nut/ Sprue Gate Tip

Use when the best flow rate for maximum gram weight is required with an allowable gate vestige. Extended tips provide extra material for customer modifications.

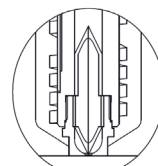

Bush Nut/ Ring Gate Tip

Ideal for applications requiring low gate vestiges processing high viscosity resins. Available with standard and wear resistant needles providing the ability to process commodity and engineered resins (filled or unfilled). Extended tips provide extra material for customer modifications.

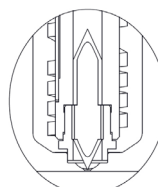

Open Nut/ Point Gate Tip

Suited for applications processing high viscosity resins where minimal gate vestige is required. Available with standard and wear resistant needles providing the ability to process commodity and engineered resins (filled or unfilled).

NOZZLE	TIP	RECOMMENDED GATE DIAMETER (RANGE)				GATE DIAMETER		RESIN MELT FLOW CAPACITY IN GRAMS		
		MINIMUM (inch)	MAXIMUM (inch)	MINIMUM (mm)	MAXIMUM (mm)	INCH	MM	Low MFI .02 - 7	Med MFI 7 - 16	High MFI 16+
PCS Mini FSB & FSBH	Sprue Gate Tip - SN	0.040	0.060	1.00	1.52	0.060	1.52	17	35	70
	Ring Gate Tip - BN	0.040	0.060	1.00	1.52	0.060	1.52	8	15	35
	Point Gate Tip - ON	0.025	0.060	0.50	1.52	0.060	1.52	8	15	35
PCS HSB Standard	Sprue Gate Tip - EF	0.078	0.078	2.00	2.00	0.078	2.00	200	400	800
	Ring Gate Tip - SN	0.059	0.078	1.50	2.00	0.078	2.00	52	105	210
	Point Gate Tip - ON	0.039	0.102	1.00	2.60	0.102	2.60	52	105	210
PCS 200 Series	Sprue Gate Tip - PID	0.078	0.078	2.00	2.00	0.078	2.00	200	400	800
	Ring Gate Tip - PMA	0.059	0.078	1.50	2.00	0.078	2.00	52	105	210
	Point Gate Tip - PVM	0.039	0.102	1.00	2.60	0.102	2.60	52	105	210
PCS 500 Series	Sprue Gate Tip - PID	0.126	0.126	3.20	3.20	0.126	3.20	300	700	1400
	Ring Gate Tip - PMA	0.078	0.098	2.00	2.50	0.098	2.50	210	490	980
	Point Gate Tip - PVM	0.039	0.118	1.00	3.00	0.118	3.00	210	490	980
PCS 800 Series	Sprue Gate Tip - PID	0.177	0.177	4.50	4.50	0.177	4.50	450	1000	2000
	Ring Gate Tip - PMA	0.098	0.118	2.50	3.00	0.118	3.00	315	700	1400
	Point Gate Tip - PVM	0.078	0.177	2.00	4.50	0.177	4.50	315	700	1400
PCS 1000 Series	Sprue Gate Tip - PID	0.197	0.197	5.00	5.00	0.197	5.00	1000	1500	3000
	Ring Gate Tip - PMA	0.118	0.138	3.00	3.50	0.138	3.50	700	1050	2100
	Point Gate Tip - PVM	0.118	0.256	3.00	6.50	0.256	6.50	700	1050	2100

HOT SPRUE BUSHING SELECTION GUIDE

Resin Application Key:

	Low MFI (.02 - 7)
	Med MFI (7 - 16)
	High MFI (16+)

	A	Amorphous Material
	C	Crystalline Material

	Good Resin Application
	Contact PCS for Application Recommendations
	Not Recommended for this Resin Application

	PBT	PC	PC+ABS	PEEK	PEI	PMMA	PPE+PS	PSU	SB	ABS	FPVC	POM	PP	PPO	PPS	PS	SAN	LCP	PA	PE	PET	PUR	TPE	TPO
Filled Resin Capability	C	A	C	C	A	C	C	C	A	C	A	C	C	A	C	A	A	C	C	C	C	A	C	C
Yes																								
Yes																								
Yes																								
Yes																								
Yes																								
Yes																								
Yes																								
Yes																								
Yes																								
Yes																								
Yes																								
Yes																								
Yes																								
Yes																								
Yes																								
Yes																								
Yes																								
Yes																								
Yes																								

PCS MINI HOT SPRUE BUSHINGS

Perfect for small parts and prototyping applications

- Economical
- Same Day Shipping
- Standard & High Performance options available
- Wear Resistant Needle available

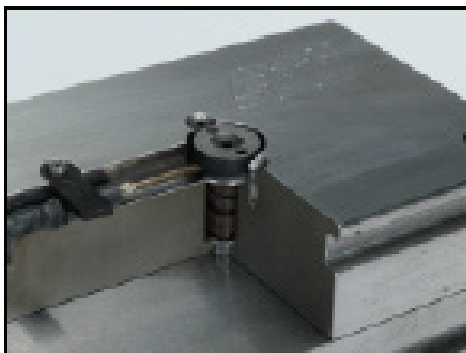

Features:

- Designed to fit standard industry tooling inserts including FITS®, MUD®, RTI® and others
- Compact design for small part and/or runner applications in A or B series mold bases
- Reduces material waste
- Helps minimize cycle time
- Available in standard inch dimensions
- With and without head heater (one or two zones of control)
- Capability to process commodity and engineered resins filled or unfilled
- J type thermocouple
- Various tip configurations
- Designed for maximum part weights up to 70 grams
- Available in Open Nut, Bush Nut and Sprue nut tips

FSB MINI HOT SPRUE BUSHINGS

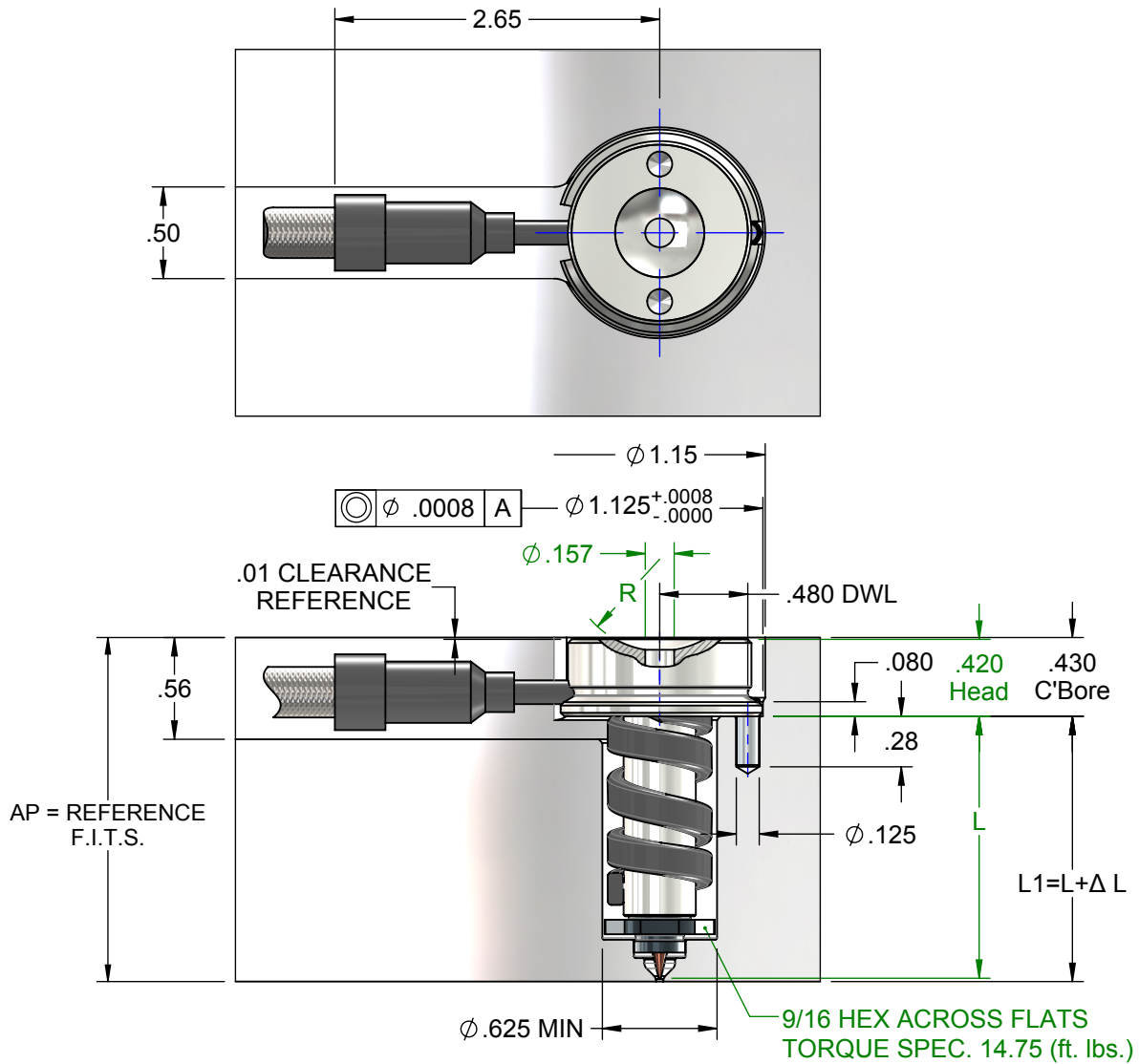

L1 = DIMENSION TO BE MAINTAINED IN MOLD

L = NOZZLE COLD LENGTH

$\Delta L = L \times 0.0000064 \times (\text{Set Point } ^\circ\text{F} - 68^\circ\text{F})$

ITEM NUMBER CONFIGURATOR



L DIMENSION	RADIUS	TIP STYLE	ORIFICE	NEEDLE TYPE
FSB17 = 1.438"	1 = .500"	ON = Open Nut	4 = .04"	S = Standard
FSB23 = 1.938"	2 = .750"	1SN = 1/2" Sprue Nut	6 = .06"	W = Wear Resistant
FSB27 = 2.438"		3SN = 3/8" Sprue Nut	4XS = .04"	Blank = Sprue Nut
FSB33 = 2.938"		1BN = 1/2" Bush Nut	6XS = .06"	
		3BN = 3/8" Bush Nut	Blank = Open Nut	

FSBH MINI HOT SPRUE BUSHINGS (High Performance)

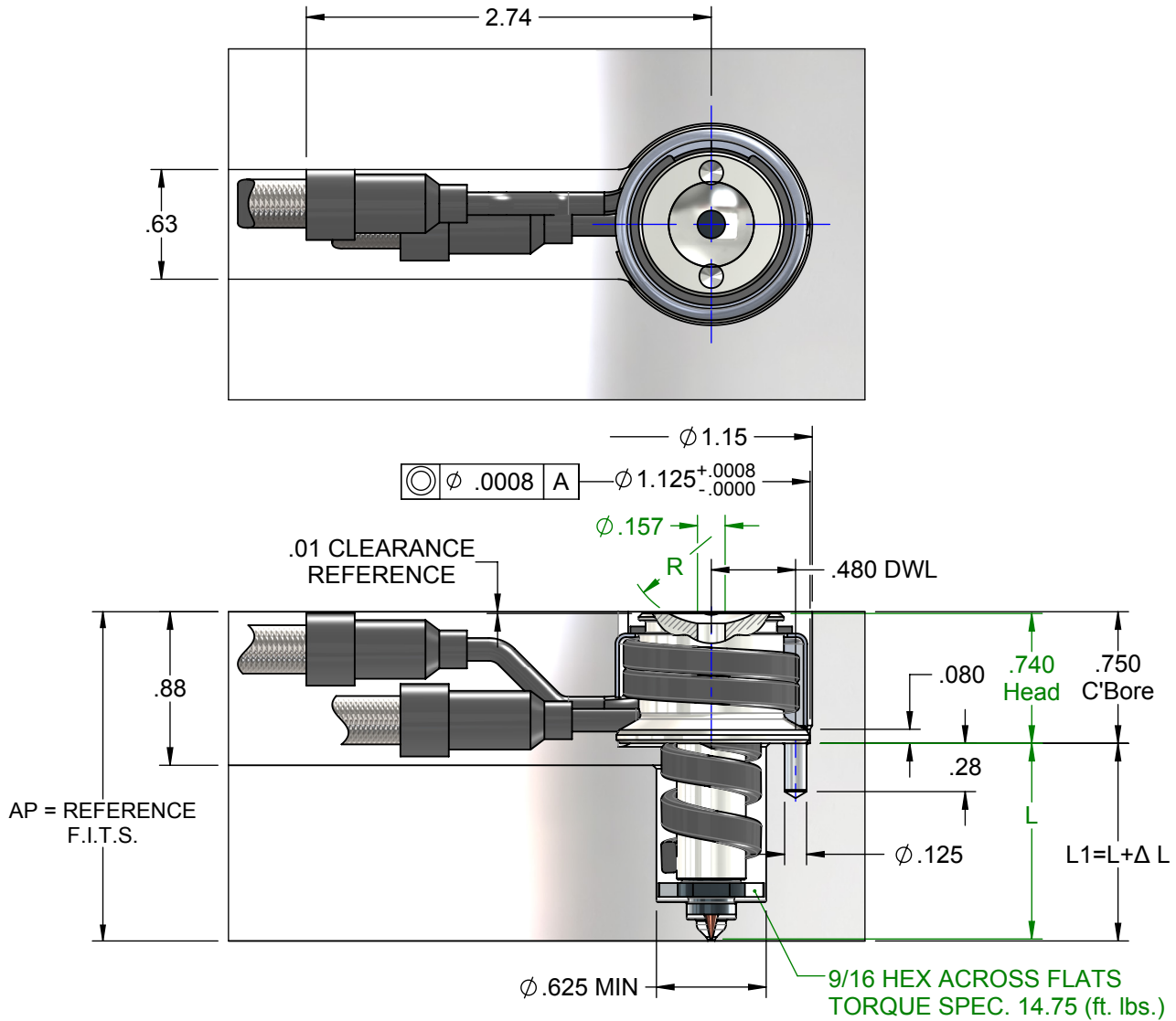

L1 = DIMENSION TO BE MAINTAINED IN MOLD

L = NOZZLE COLD LENGTH

$\Delta L = L \times 0.0000064 \times (\text{Set Point } ^\circ\text{F} - 68^\circ\text{F})$

ITEM NUMBER CONFIGURATOR



L DIMENSION	RADIUS	TIP STYLE	ORIFICE	NEEDLE TYPE
FSBH17 = 1.125"	1 = .500"	ON = Open Nut	4 = .04"	S = Standard
FSBH23 = 1.625"	2 = .750"	1SN = 1/2" Sprue Nut	6 = .06"	W = Wear Resistant
FSBH27 = 2.125"		3SN = 3/8" Sprue Nut	4XS = .04"	Blank = Sprue Nut
FSBH33 = 2.625"		1BN = 1/2" Bush Nut	6XS = .06"	
		3BN = 3/8" Bush Nut	Blank = Open Nut	

FSB & FSBH MINI TIP DETAIL

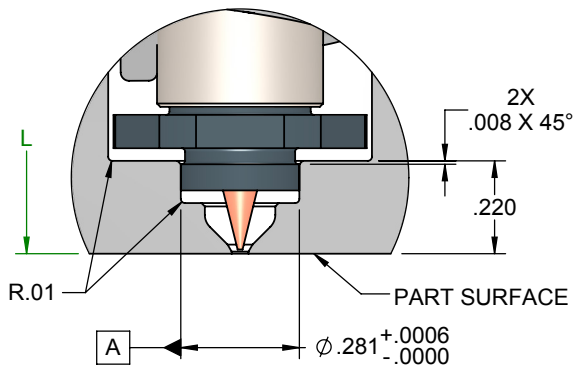

ON TIP
Open Nut/Point Tip

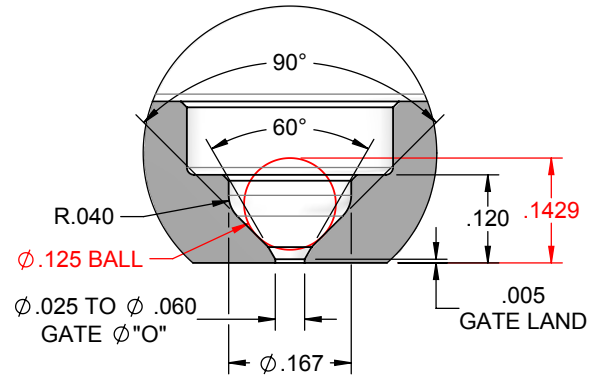

ON GATE DETAIL

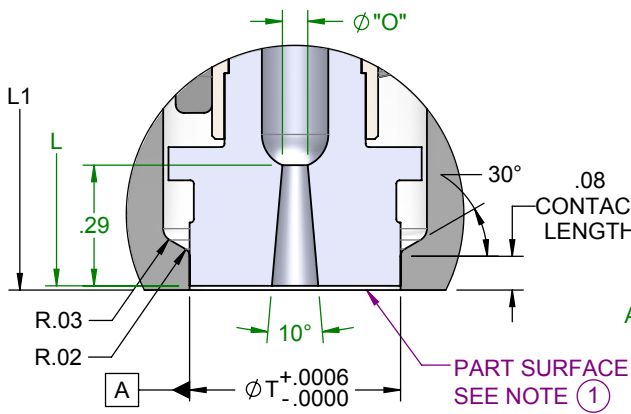

SN TIP
Sprue Nut

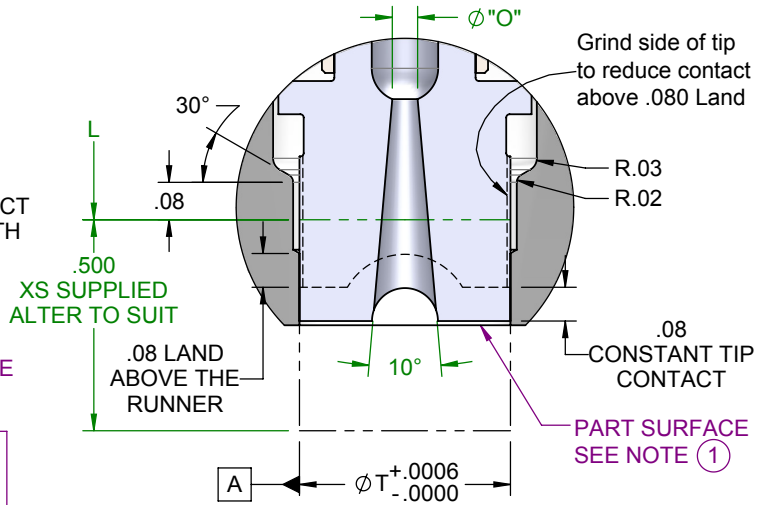

SN XS TIP
Sprue Nut With Extra Stock

① Nozzle shown in cold state. If gating to runner, avoid tip contact with steel on the parting line to help prevent heat loss. A setback of .003 Min. when hot is recommended.

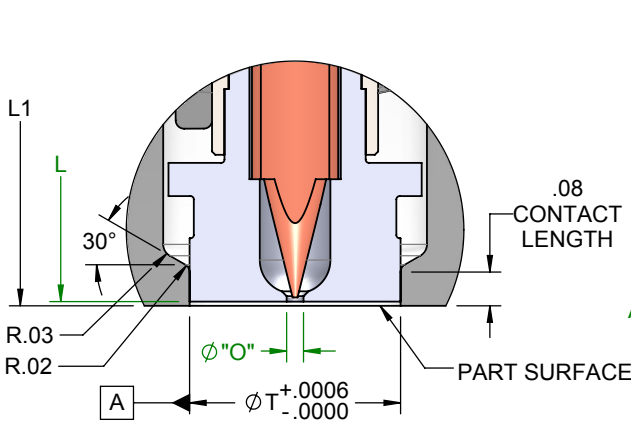

BN TIP
Bush Nut/Ring Gate

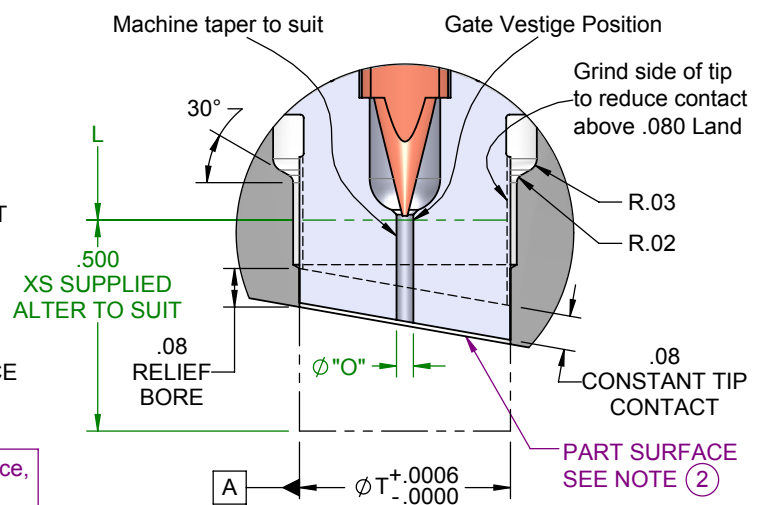

BN XS TIP
Bush Nut/Ring Gate With Extra Stock

② Nozzle shown in cold state. When gating onto part surface, allow for thermal expansion.

Mini FSB & FSBH Locating Ring for Dedicated Mold Bases

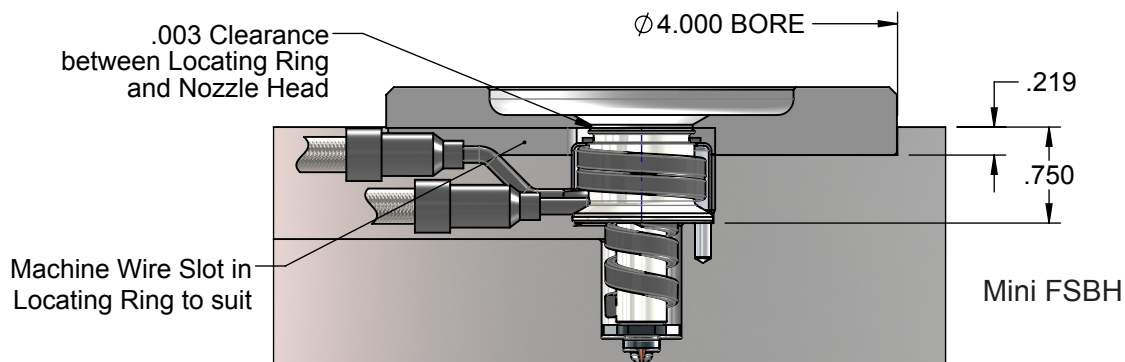
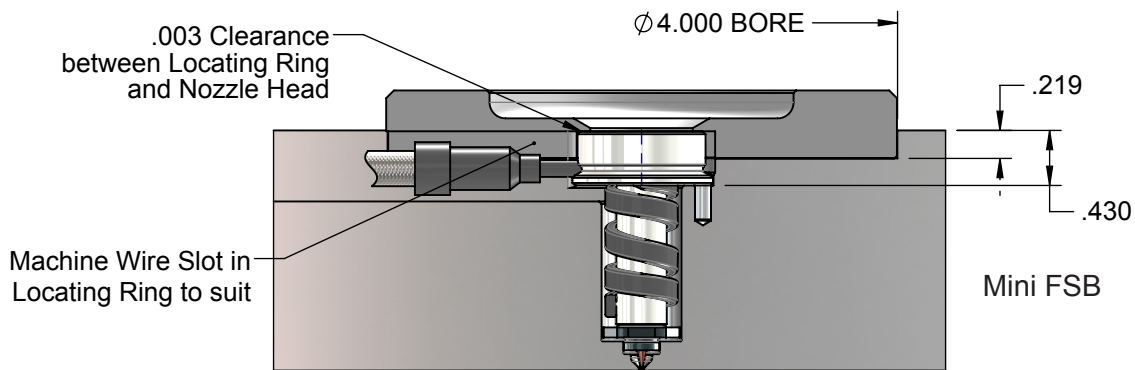
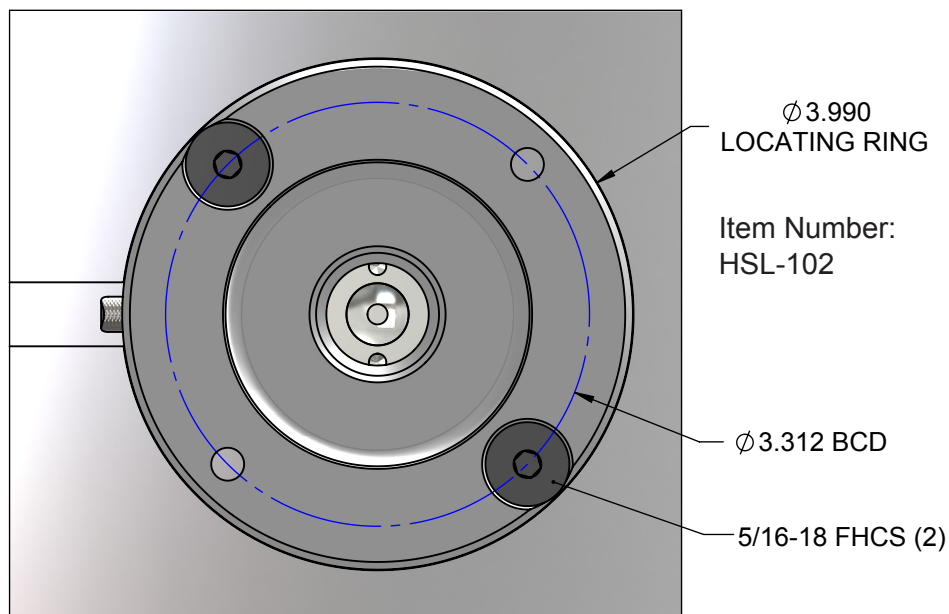

Mini Hot Sprue Companion Temperature Controllers & F.I.T.S.

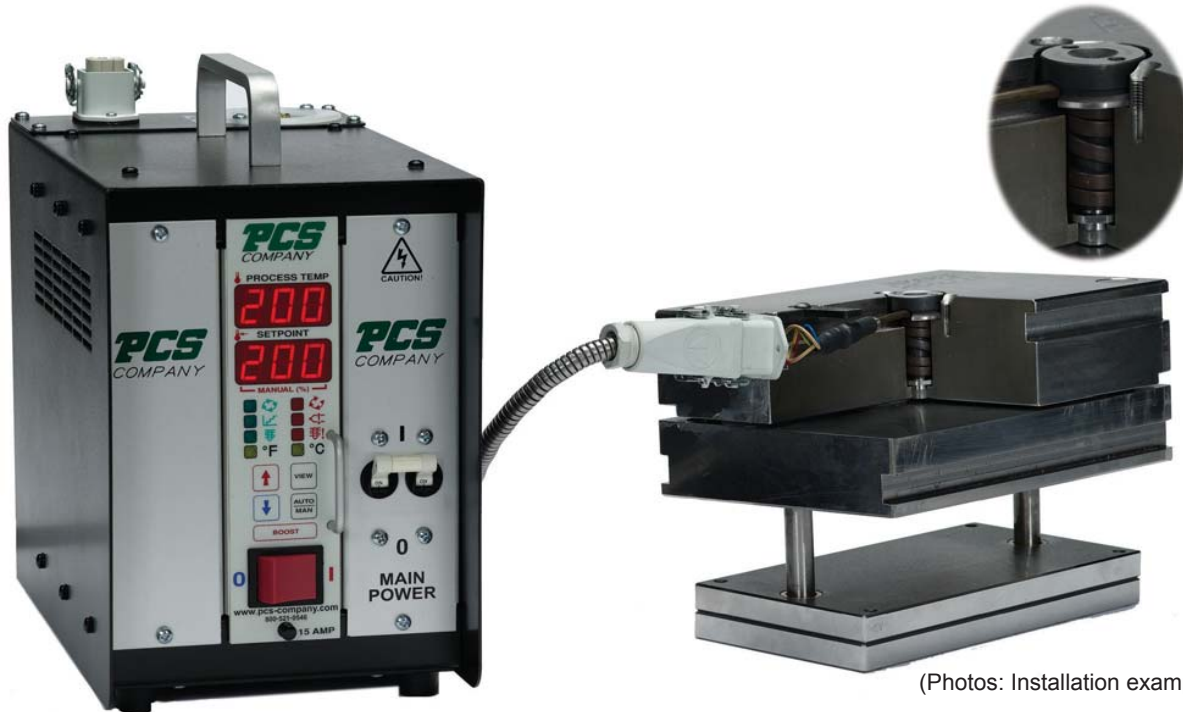

(Photos: Installation example only)



VC-1F

VC-1ZF

VC-2F

VC-M

VC-MPTC-15

CKPTIC-1

PCS Mini Hot Sprue Bushing and F.I.T.S Sizing Chart

	FSB-17 / FSBH-17		FSB-23 / FSBH-23		FSB-27 / FSBH-27	FSB-33/FSBH-33
	L = 1 7/8"		L = 2 3/8"		L = 2 7/8"	L=3 3/8"
F.I.T.S Part Numbers	Solid	Laminated	Solid	Laminated	Laminated	To be used with thicker plates and standard mold bases
	FTS-0809-223-X	FTL-0809-284-X	FTS-0809-226	FTL-0809-286	FTL-0809-289	
	FTS-0809-224-X	FTL-0809-284	FTS-0809-227	FTL-0809-287	FTL-0809-290	
	FTS-0809-223	FTL-0809-285	FTS-0810-226	FTL-0809-288	FTL-0810-289	
	FTS-0809-224	FTT-0809-203	FTS-0810-227	FTT-0809-206	FTL-0810-290	
	FTS-0809-225	FTL-0810-284	FTS-8490-226	FTL-0810-286	FTL-8490-286	
	FTS-0810-223	FTL-0810-285	FTS-8490-227	FTL-0810-287	FTL-8490-287	
	FTS-0810-224	FTL-0810-285	FTS-1012-226	FTL-0810-288	FTL-1012-288	
	FTS-0810-225	FTT-0810-203	FTS-1012-227	FTT-0810-206	FTL-1012-289	
	FTS-8490-223	FTL-8490-281		FTL-8490-283		
	FTS-8490-224	FTL-8490-282		FTL-8490-284		
	FTS-8490-225	FTT-8490-204		FTL-8490-285		
	FTS-1012-224			FTT-8490-207		
	FTS-1012-225			FTL-1012-285		
			FTL-1012-286			

PCS Standard HSB



- Replaces the standard cold sprue bushing
- Reduces material waste
- Helps minimize cycle time
- Available in standard inch and metric dimensions
- Standard and High Performance hot sprue bushing assemblies available
- Capability to process commodity and engineered resins filled or unfilled
- Heaters rated at 240 VAC
- J type thermocouple
- Spare thermocouple for the nozzle body
- Various tip configurations
- Designed for total shot weights up to 3000 grams
- 2D & 3D CAD data online at www.pcs-company.com

CATALOG NUMBER CONFIGURATOR

HSB-18 - 2 - EF-100XS - 2

L DIMENSION	RADIUS	TIP STYLE	T DIMENSION AND DESCRIPTION	HEAD HEATER
HSB-13 = 1.375"	1 = .500"	ON	= Open Nut	1 = EXCLUDE
HSB-18 = 1.875"	2 = .750"	ON-W	= Open Nut w/ Wear Resistant Needle	2 = INCLUDED
HSB-23 = 2.375"		SN-075	= 0.750"Ø T/ Bush Nut (.059"Ø Gate Orifice)	
HSB-28 = 2.875"		SN-075W	= 0.750"Ø T/ Bush Nut w/ Wear Resistant Needle (.059"Ø Gate Orifice)	
HSB-33 = 3.375"		SN-075XS	= 0.750"Ø T/ Bush Nut Extra Stock (.059"Ø Gate Orifice)	
HSB-38 = 3.875"		SN-075XSW	= 0.750"Ø T/ Bush Nut Extra Stock w/ Wear Resistant Needle (.059"Ø Gate Orifice)	
HSB-43 = 4.375"		SN-100	= 1.000"Ø T/ Bush Nut (.059"Ø Gate Orifice)	
		SN-100W	= 1.000"Ø T/ Bush Nut w/ Wear Resistant Needle (.059"Ø Gate Orifice)	
		SN-100XS	= 1.000"Ø T Bush Nut Extra Stock (.059"Ø Gate Orifice)	
		SN-100XSW	= 1.000"Ø T/ Bush Nut Extra Stock w/ Wear Resistant Needle (.059"Ø Gate Orifice)	
		EF-075	= 0.750"Ø T/ Sprue Nut (.078"Ø Gate Orifice)	
		EF-075XS	= 0.750"Ø T/ Sprue Nut Extra Stock (.125"Ø Gate Orifice)	
		EF-075XS078	= 0.750"Ø T/ Sprue Nut Extra Stock (.078"Ø Gate Orifice)	
		EF-100	= 1.000"Ø T/ Sprue Nut (.078"Ø Gate Orifice)	
		EF-100XS	= 1.000"Ø T/ Sprue Nut Extra Stock (.125"Ø Gate Orifice)	
		EF-100XS-078	= 1.000"Ø T/ Sprue Nut Extra Stock (.078"Ø Gate Orifice)	
		SE-075	= 0.750"Ø T/ Bush Nut with Sprue (.078"Ø Gate Orifice)	
		SE-075W	= 0.750"Ø T/ Bush Nut with Sprue w/ Wear Resistant Needle (.078"Ø Gate Orifice)	
		SE-100	= 1.000"Ø T/ Bush Nut with Sprue (.078"Ø Gate Orifice)	
		SE-100W	= 1.000"Ø T/ Bush Nut with Sprue w/ Wear Resistant Needle (.078"Ø Gate Orifice)	

PCS Standard HSB

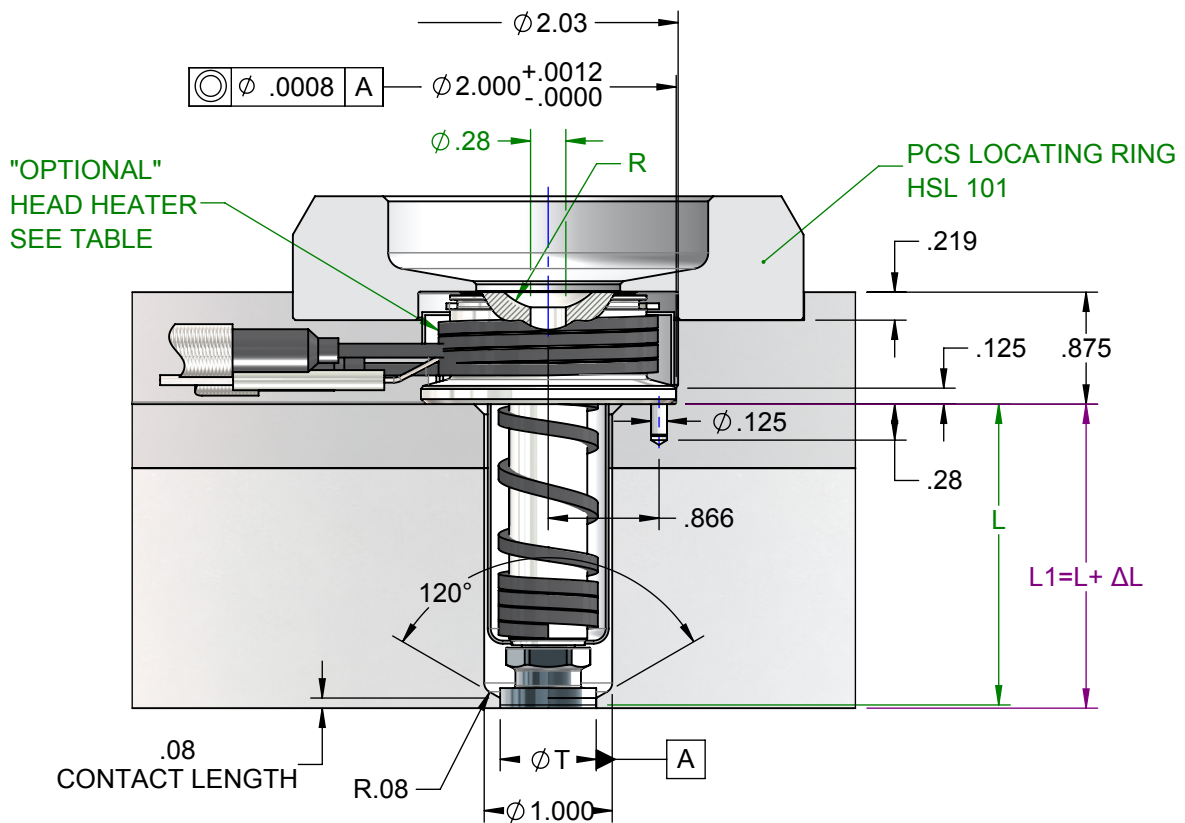
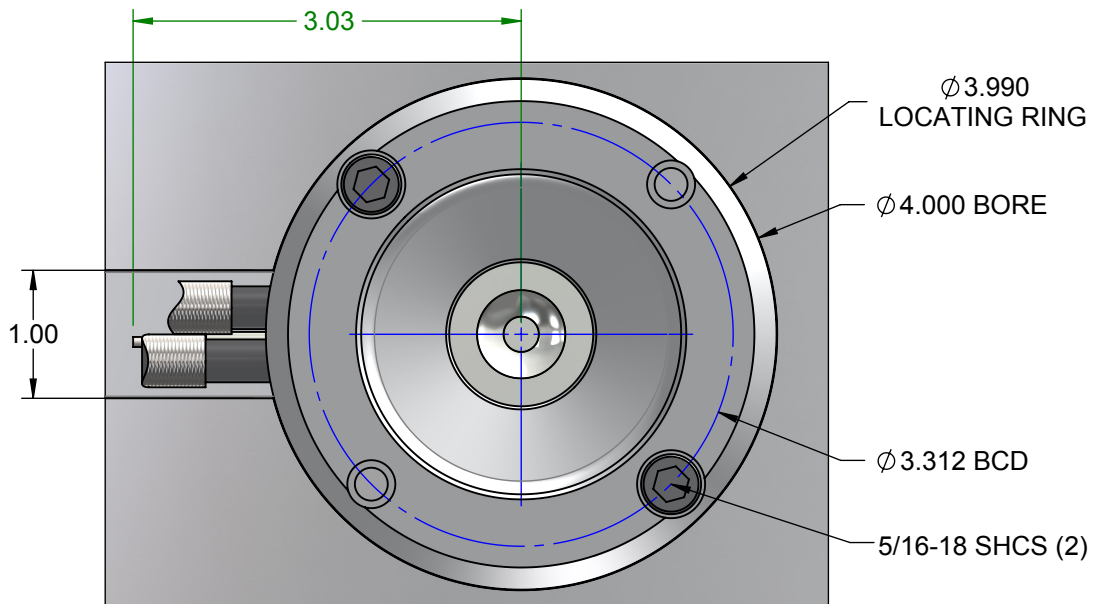

L1 = DIMENSION TO BE MAINTAINED IN MOLD

L = NOZZLE COLD LENGTH

$\Delta L = L \times 0.000064 \times (\text{Set Point } ^\circ\text{F} - 68^\circ\text{F})$

PCS HSB TIP DETAIL

Open Nut/
Point Gate

ON

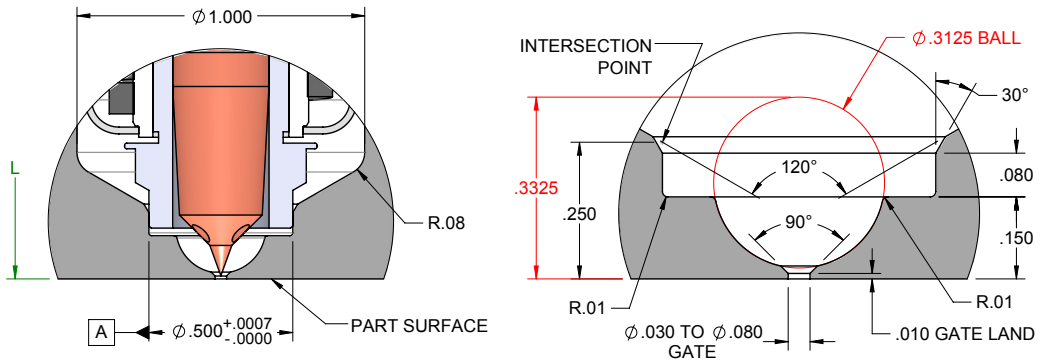

Bush Nut/
Ring Gate

SN
&
SN XS

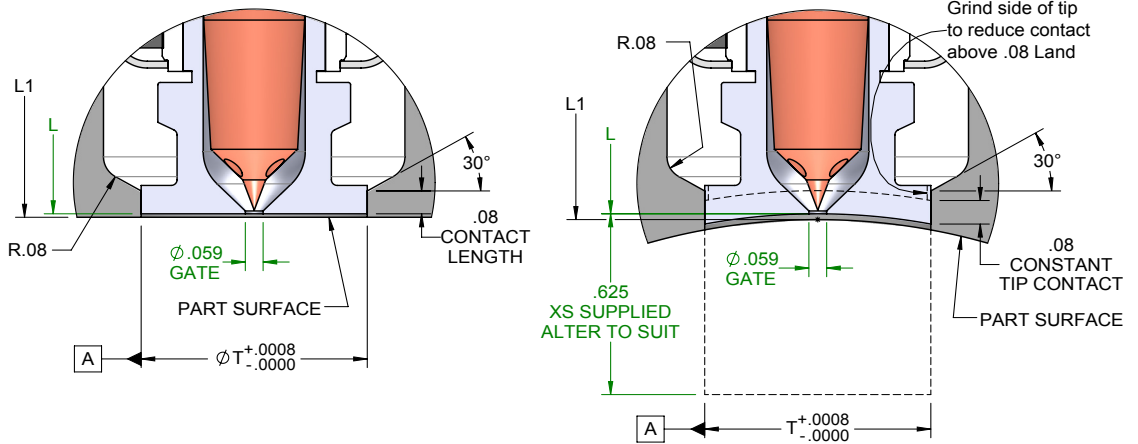

Sprue Nut/
Sprue Gate

EF
&
EF XS

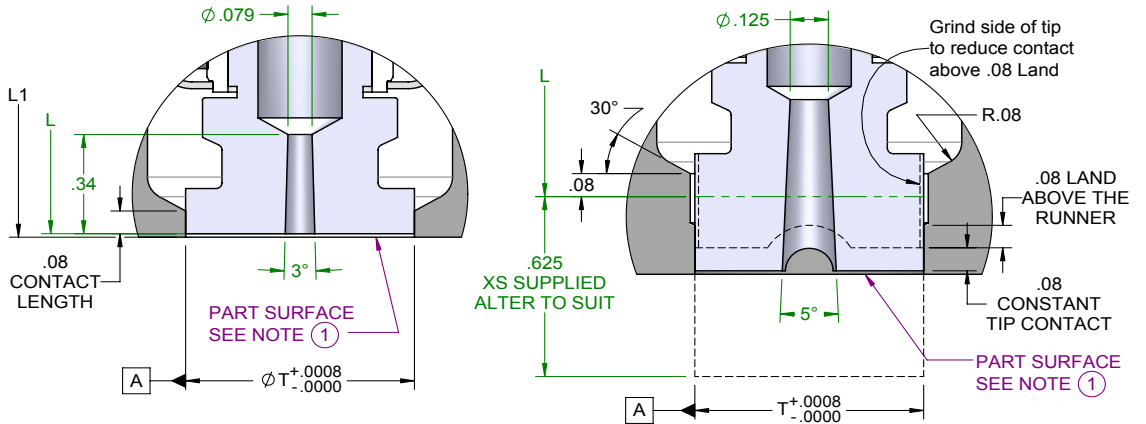

Sprue Nut/
Sprue Gate

SE to control stringing

① Nozzle shown in cold state. If gating to runner, avoid tip contact with steel on the parting line to help prevent heat loss. A setback of .003 Min. when hot is recommended.

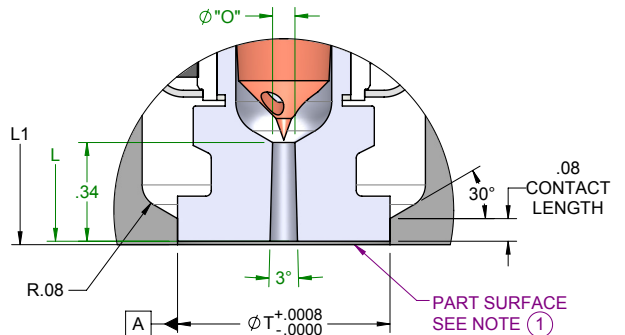

PCS STRIPPER PLATE BUSHING

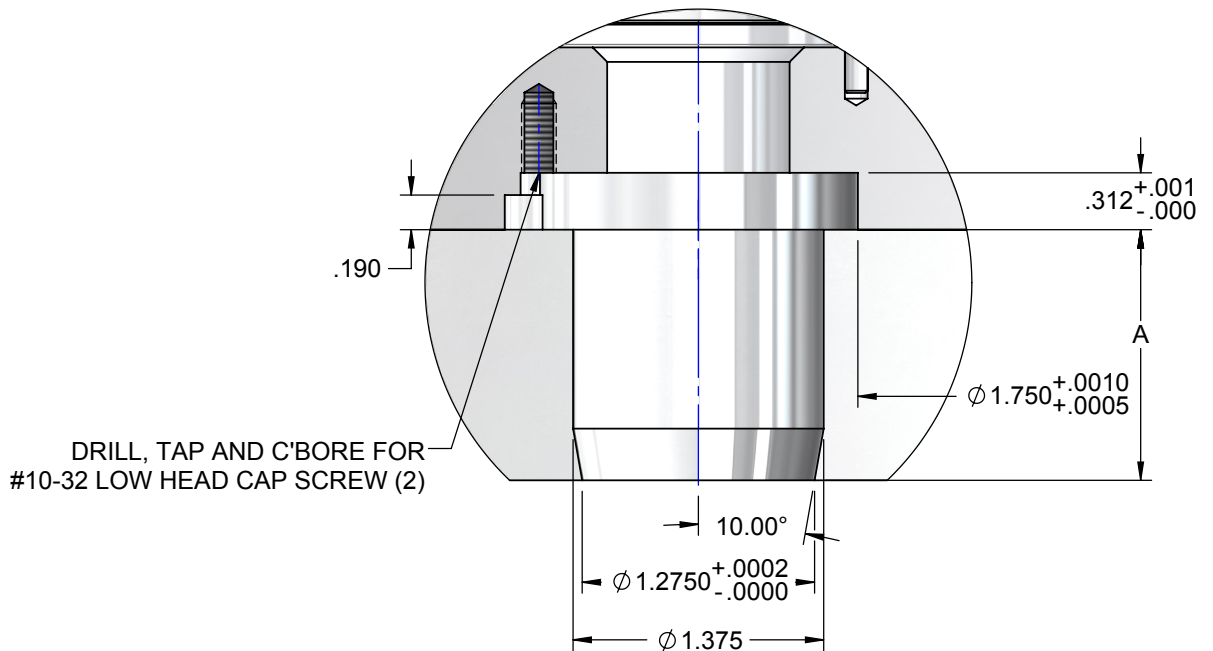
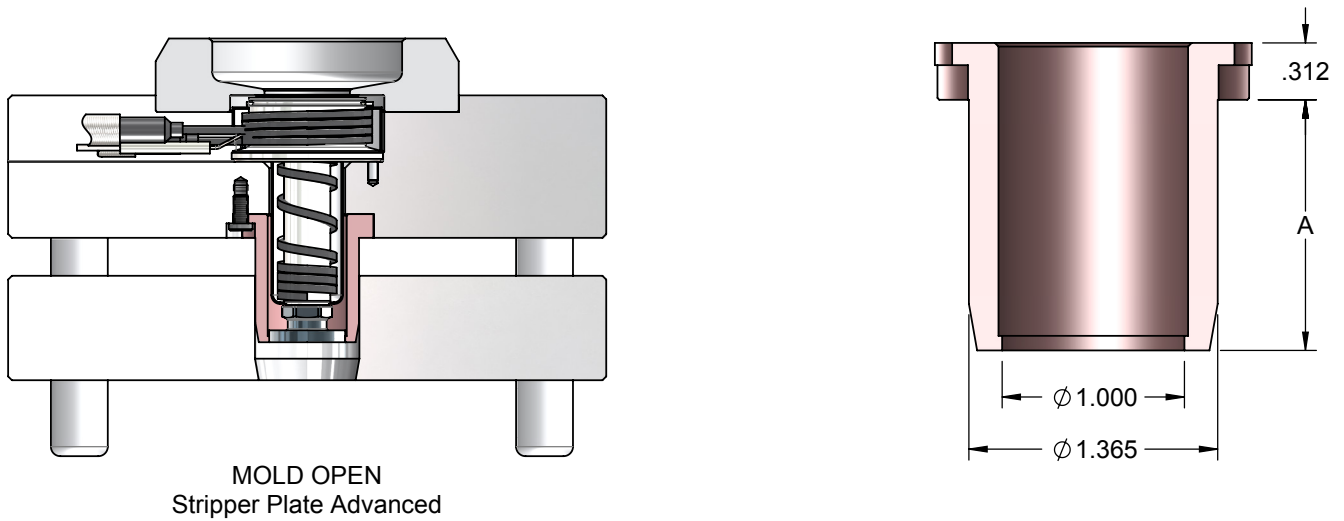
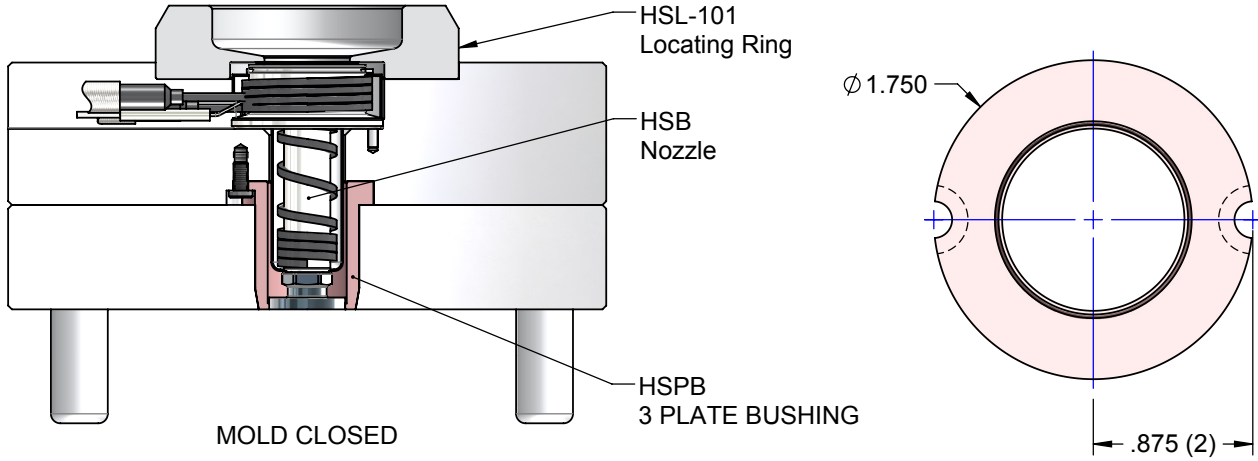

FSB & FSBH Mini Hot Sprue Bushing Spare Parts

FSB Parts



Item Number	Item Description
FSB17-1-BD	L=1.875" R=.500"
FSB17-2-BD	L=1.875" R=.750"
FSB23-1-BD	L=2.375" R=.500"
FSB23-2-BD	L=2.375" R=.750"
FSB27-1-BD	L=2.875" R=.500"
FSB27-2-BD	L=2.875" R=.750"
FSB33-1-BD	L=3.375" R=.500"
FSB33-2-BD	L=3.375" R=.750"



Item Number	Wattage	Item Description
FSH-17	150W	Body heater with built in Thermocouple
FSH-23	200W	
FSH-27	225W	
FSH-33	250W	



Item Number	Item Description
FSN-S	Standard Needle
FSN-W	Wear-Resistant Needle



Item Number	Item Description
FSB-3BN-4	Bush Nut, .040" Orifice, T=3/8"
FSB-3BN-6	Bush Nut, .060" Orifice, T=3/8"
FSB-1BN-4	Bush Nut, .040" Orifice, T=1/2"
FSB-1BN-6	Bush Nut, .060" Orifice, T=1/2"
FSB-ON	Open Nut Tip
FSB-1SN-4	Sprue Nut, .040" Orifice, T=1/2"
FSB-1SN-6	Sprue Nut, .060" Orifice, T=1/2"
FSB-3SN-4	Sprue Nut, .040" Orifice, T=3/8"
FSB-3SN-6	Sprue Nut, .060" Orifice, T=3/8"
FSB-3BN-4XS	Bush Nut, XS .040" Orifice, T=3/8"
FSB-3BN-6XS	Bush Nut, XS .060" Orifice, T=3/8"
FSB-1BN-4XS	Bush Nut, XS .040" Orifice, T=1/2"
FSB-1BN-6XS	Bush Nut, XS .060" Orifice, T=1/2"
FSB-3SN-4XS	Sprue Nut, XS .040" Orifice, T=3/8"
FSB-3SN-6XS	Sprue Nut, XS .060" Orifice, T=3/8"
FSB-1SN-4XS	Sprue Nut, XS .040" Orifice, T=1/2"
FSB-1SN-6XS	Sprue Nut, XS .060" Orifice, T=1/2"

Accessories



Item Number	Item Description
HSL-102	Locating Ring for FSB/FSBH Dedicated Mold Bases

FSBH Parts

Item Number	Item Description
HS-200	Snap Ring



Item Number	Item Description
HHR-200	Head Heater Cover



Item Number	Wattage	Item Description
HH-200	125W	Head Heater with built in Thermocouple



Item Number	Item Description
FSBH-17-1-BD	L=1.875" R=.500"
FSBH-17-2-BD	L=1.875" R=.750"
FSBH-23-1-BD	L=2.375" R=.500"
FSBH-23-2-BD	L=2.375" R=.750"
FSBH-27-1-BD	L=2.875" R=.500"
FSBH-27-2-BD	L=2.875" R=.750"
FSBH-33-1-BD	L=3.375" R=.500"
FSBH-33-2-BD	L=3.375" R=.750"



Item Number	Wattage	Item Description
FSHH-17	125W	Body heater with built in Thermocouple
FSHH-23	200W	
FSHH-27	200W	
FSHH-33	225W	



Item Number	Item Description
FSN-S	Standard Needle
FSN-W	Wear-Resistant Needle



Item Number	Item Description
FSB-3BN-4	Bush Nut, .040" Orifice, T=3/8"
FSB-3BN-6	Bush Nut, .060" Orifice, T=3/8"
FSB-1BN-4	Bush Nut, .040" Orifice, T=1/2"
FSB-1BN-6	Bush Nut, .060" Orifice, T=1/2"
FSB-ON	Open Nut Tip
FSB-1SN-4	Sprue Nut, .040" Orifice, T=1/2"
FSB-1SN-6	Sprue Nut, .060" Orifice, T=1/2"
FSB-3SN-4	Sprue Nut, .040" Orifice, T=3/8"
FSB-3SN-6	Sprue Nut, .060" Orifice, T=3/8"
FSB-3BN-4XS	Bush Nut, XS .040" Orifice, T=3/8"
FSB-3BN-6XS	Bush Nut, XS .060" Orifice, T=3/8"
FSB-1BN-4XS	Bush Nut, XS .040" Orifice, T=1/2"
FSB-1BN-6XS	Bush Nut, XS .060" Orifice, T=1/2"
FSB-3SN-4XS	Sprue Nut, XS .040" Orifice, T=3/8"
FSB-3SN-6XS	Sprue Nut, XS .060" Orifice, T=3/8"
FSB-1SN-4XS	Sprue Nut, XS .040" Orifice, T=1/2"
FSB-1SN-6XS	Sprue Nut, XS .060" Orifice, T=1/2"



Standard HSB Hot Sprue Bushing Spare Parts



Item Number	Item Description
HS-100	Snap Ring



Item Number	Item Description
HR-100	Head Heater Cover



Item Number	Wattage	Item Description
HH-100	250W	Head Heater with built in Thermocouple



Item Number	Item Description
HSB-13-1-BD	L=1.375" R=.500"
HSB-13-2-BD	L=1.375" R=.750"
HSB-18-1-BD	L=1.875" R=.500"
HSB-18-2-BD	L=1.875" R=.750"
HSB-23-1-BD	L=2.375" R=.500"
HSB-23-2-BD	L=2.375" R=.750"
HSB-28-1-BD	L=2.875" R=.500"
HSB-28-2-BD	L=2.875" R=.750"
HSB-33-1-BD	L=3.375" R=.500"
HSB-33-2-BD	L=3.375" R=.750"
HSB-38-1-BD	L=3.875" R=.500"
HSB-38-1-BD	L=3.875" R=.750"
HSB-43-1-BD	L=4.375" R=.500"
HSB-43-2-BD	L=4.375" R=.750"



Item Number	Item Description
HST-13	Spare Nozzle Body Thermocouple
HST-18-23	
HST-28-33	
HST-38	
HST-43	



Item Number	Wattage	Item Description
HSH-13	225W	Body Heater with built in Thermocouple
HSH-18	250W	
HSH-23	300W	
HSH-28	350W	
HSH-33	400W	
HSH-38	450W	
HSH-43	450W	



Item Number	Item Description
HSR-13	Body Heater Cover
HSR-18	
HSR-23	
HSR-28	
HSR-33	
HSR-38	
HSR-43	

Item Number	Item Description
TE-10	Standard Needle-SE Tip
WTE-10	Wear Resistant Needle-SE Tip
TN-10	Standard Needle-SN, ON Tip
WTN-10	Wear Resistant Needle-SN, ON Tip



Item Number	Item Description
EF-075	EF Style, Tip Dia.=.075"
EF-075XS	EF Style, XS, O=.125" Tip Dia.=.075"
EF-075XS-078	EF Style, XS, O=.078" Tip Dia.=.075"
SN-075	SN Style, Tip Dia.=.075"
SN-075XS	SN Style, XS, Tip Dia.=.075"
SE-075	SE Style, Tip Dia.T=.075"
EF-100	EF Style, Tip Dia.=1.000"
EF-100XS	EF Style, XS, Tip Dia.=1.000"
SN-100	SN Style, Tip Dia.=1.000"
SN-100XS	SN Style, XS, Tip Dia.=1.000"
SE-100	SE Style, Tip Dia.=1.000"
HSB-ON	Open Nut Tip



Accessories

Item Number	Item Description
HSL-101	Locating Ring for HSB



Item Number	A Dimension	Item Description
HSPB-13	1.375	HSB Stripper
HSPB-18	1.875	Plate Bushing



200 Series Tips

SPRUE GATE TIP (x NOTES EXTENDED TIP LENGTH)

Standard Sprue Tip

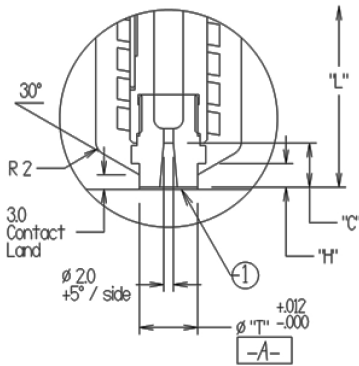

TIP DIMENSIONS			
PART NUMBER	DIMENSION "T"	DIMENSION "H"	DIMENSION "C"
PDO6001	12.00	5.50	9.00
PDO6002	18.00	5.50	9.00
PDO6002-1	1.000"	5.50	9.00
PDO6003 x	12.00	23.50	27.00
PDO6004 x	18.00	23.50	27.00
PDO6004-1 x	1.000"	23.50	27.00

Max. Torque
40 [Nxm] / 295 Ft-Lbs
12 Point Deep Socket Req'd
14mm or 20mm

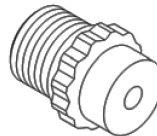

Extended Sprue Tip

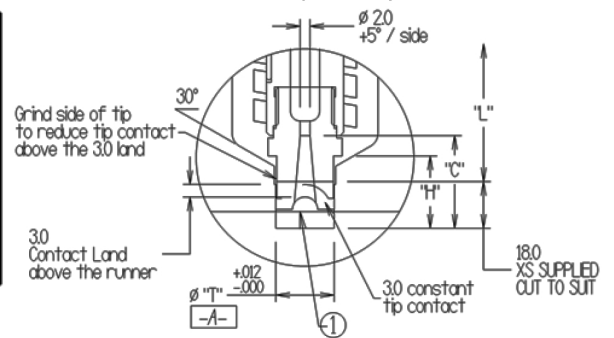

① NOTE: Nozzle shown in cold state. If gating into a runner, avoid tip contact with steel on the parting line to prevent heat loss. A setback of .003 Min. when hot is recommended.

Standard Ring Gate Tip

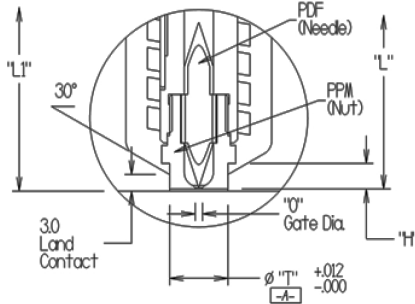

RING GATE TIP (x NOTES EXTENDED TIP LENGTH)

TIP DIMENSIONS						
TP ASM #	TIP COMPONENTS		MATERIAL	DIMENSION "T"	DIMENSION "O"	DIMENSION "H"
	NEEDLE	NUT				
PMA06009-A	PDF06502	PPM06601	ABRASION RESISTANT NEEDLE	12.00	1.50	5.50
PMA06010-A		PPM06602		12.00	2.00	
PMA06011-A		PPM06603		18.00	1.50	
PMA06012-A		PPM06604		18.00	2.00	
PMA06013-Ax		PPM06605		23.50	12.00	1.50
PMA06014-Ax		PPM06606			12.00	2.00
PMA06015-Ax		PPM06607			18.00	1.50
PMA06016-Ax		PPM06608			18.00	2.00
PMA06001-A	PDF06702	PPM06601	Standard NEEDLE (Coated in "Cr")	12.00	1.50	5.50
PMA06002-A		PPM06602		12.00	2.00	
PMA06003-A		PPM06603		18.00	1.50	
PMA06004-A		PPM06604		18.00	2.00	
PMA06005-Ax		PPM06605		23.50	12.00	1.50
PMA06006-Ax		PPM06606			12.00	2.00
PMA06007-Ax		PPM06607			18.00	1.50
PMA06008-Ax		PPM06608			18.00	2.00

Extended Ring Gate Tip

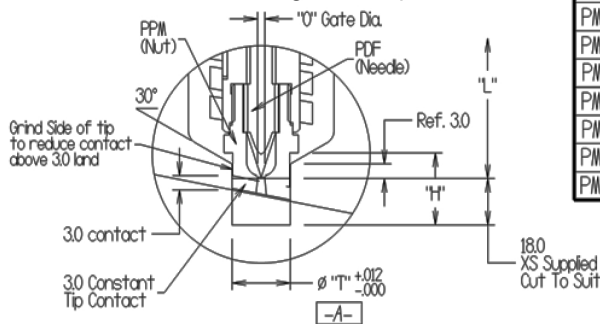

Max. Torque
40 [Nxm] / 295 Ft-Lbs
12 Point Deep Socket Req'd
14mm or 20mm

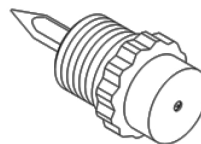

Open Nut Point Gate Tip

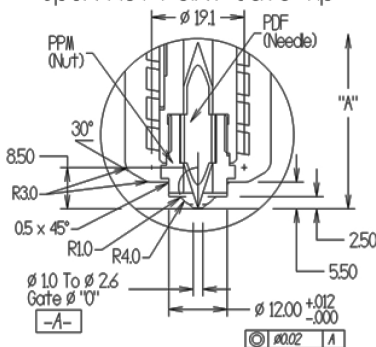

Open Nut Point Gate Tip

TP ASM #	Tip Components		
	NEEDLE	NUT	MATERIAL
PVMO6002	PDF06502	PPM06609	Abrasion Resistant
PVMO6001	PDF06702	PPM06609	Standard (Coated in "Cr")

DIAMETER GATE	DIMENSION "B"	DIMENSION "C"
Ø1.0	Ø2.00	2.06
Ø1.2		1.96
Ø1.4		1.86
Ø1.6	Ø3.00	2.97
Ø1.8		2.87
Ø2.0		2.77
Ø2.2		3.88
Ø2.4	Ø4.00	3.78
Ø2.6		3.68

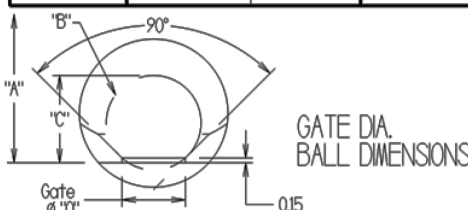

Max. Torque
30 [Nxm] / 22 Ft - Lbs
12 Point Deep Socket Req'd
14mm

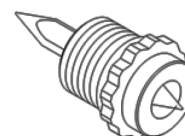

500 Series High Performance Hot Sprue Bushings

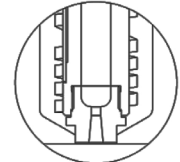
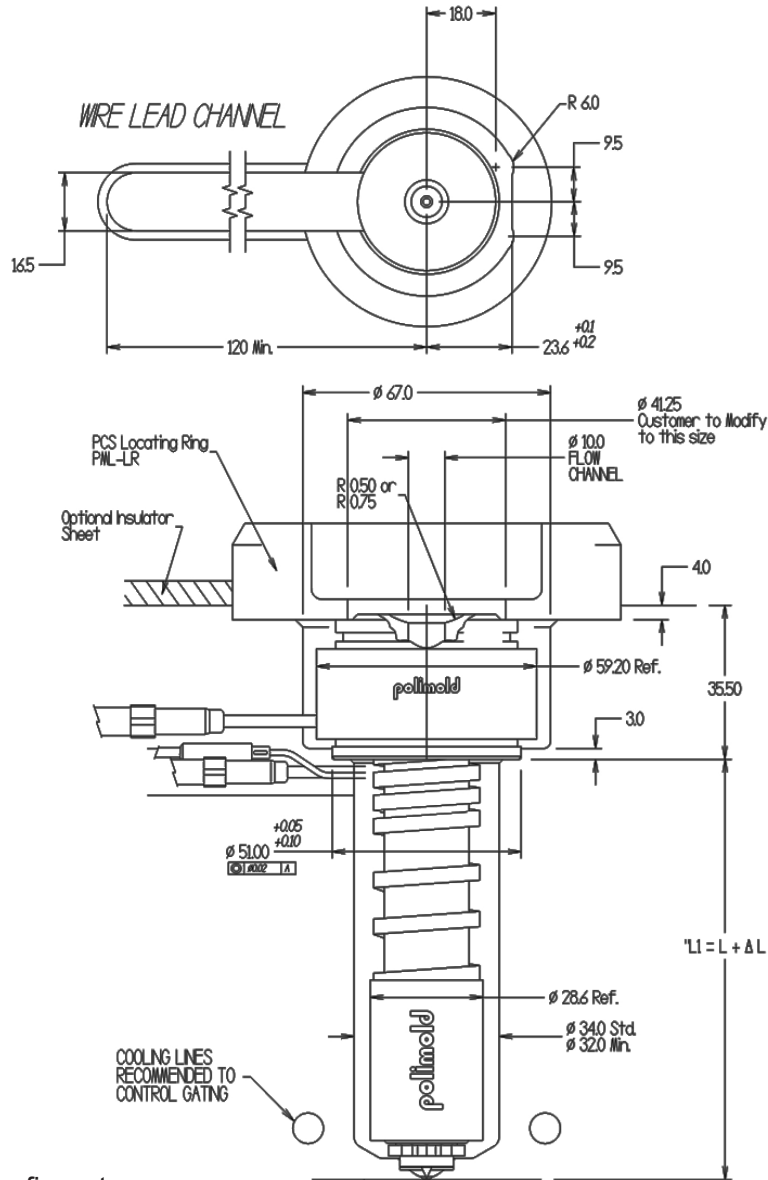

Standard Sprue Tip

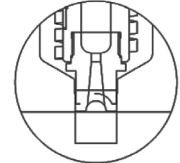

Extended Sprue Tip

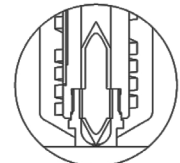

Standard Ring Gate Tip

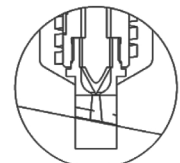

Extended Ring Gate Tip

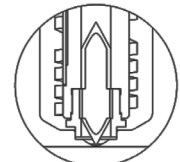

Open Nut / Point Gate Tip

Catalog Number Configurator:

EDP10185 - R050

PART SURFACE

BUSHING THERMAL EXPANSION
 $\Delta L = L \times .0000064 \times (\text{Setpoint } ^\circ\text{F} - 68^\circ\text{F})$

NOZZLE CATALOG NUMBER	RADIUS CODE	R DIM.	L DIM.	COMPONENTS					
				NOZZLE BODY	BODY HEATER	WATTAGE	BODY THERMOCOUPLE	HEAD HEATER	WATTAGE
EDP10035	R050	1/2"	35.00	CEP10035-A	RBP10036	350W	TMP01080	RCP50020	400W
EDP10060	R070	3/4"	60.00	CEP10060-A	RBP10056	500W	TMP01080		
EDP10072			72.50	CEP10072-A	RBP10069	690W	TMP01100		
EDP10085			85.00	CEP10085-A	RBP10081	760W	TMP01120		
EDP10097			97.50	CEP10097-A	RBP10094	760W	TMP01140		
EDP10110			110.00	CEP10110-A	RBP10107	760W	TMP01160		
EDP10135			135.00	CEP10135-A	RBP10131	850W	TMP01180		
EDP10160			160.00	CEP10160-A	RBP10158	1100W	TMP01200		
EDP10185			185.00	CEP10185-A	RBP10183	1300W	TMP01220		
EDP10210			210.00	CEP10210-A	RBP10208	1100W	TMP01240		
EDP10235			235.00	CEP10235-A	RBP10233	1300W	TMP01260		
EDP10260			260.00	CEP10260-A	RBP10258	1300W	TMP01280		
EDP10285			285.00	CEP10285-A	RBP10283	1300W	TMP01300		

500 Series Tips

SPRUE GATE TIP

(x NOTES EXTENDED TIP LENGTH)

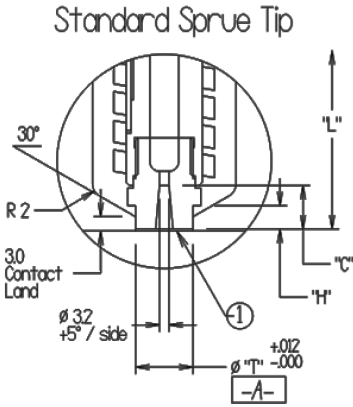

TP DIMENSIONS			
PART NUMBER	DIMENSION "T"	DIMENSION "H"	DIMENSION "C"
PD10001	14.00	6.00	9.00
PD10002	18.00	6.00	9.00
PD10002-1	1.000"	6.00	9.00
PD10003 x	14.00	24.00	27.00
PD10004 x	18.00	24.00	27.00
PD10004-1 x	1.000"	24.00	27.00

Max. Torque
55 [N·m] / 405 Ft-Lbs
12 Point Deep Socket Req'd
17mm or 20mm

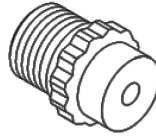

Extended Sprue Tip

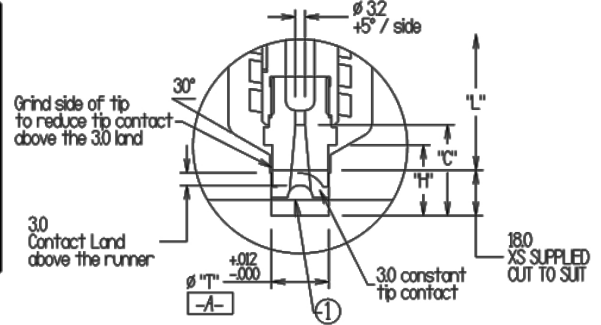

① NOTE: Nozzle shown in cold state. If gating into a runner, avoid tip contact with steel on the parting line to prevent heat loss. A setback of .003 Min. when hot is recommended.

Standard Ring Gate Tip

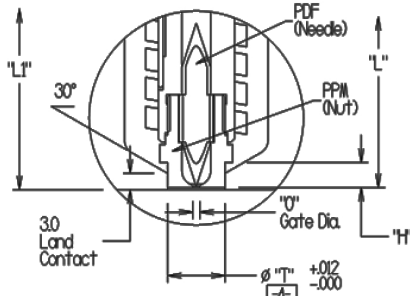

Extended Ring Gate Tip

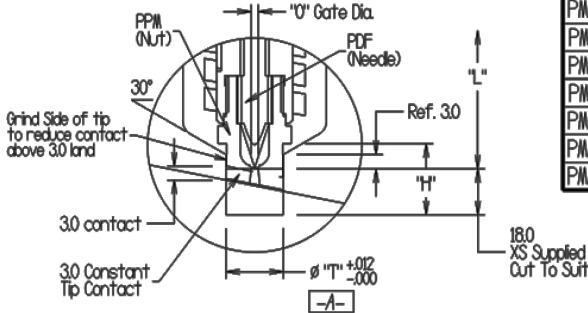

RING GATE TIP

(x NOTES EXTENDED TIP LENGTH)

TP DIMENSIONS							
TP ASM #	TP COMPONENTS		MATERIAL	DIMENSION "T"	DIMENSION "O"	DIMENSION "H"	
	NEEDLE	NUT					
PMA10009-A	PDF10502	PPM10601	ABRASION RESISTANT NEEDLE	14.00	2.00	6.00	
PMA10010-A		PPM10602		14.00	2.50		
PMA10011-A		PPM10603		18.00	2.00		
PMA10012-A		PPM10604		18.00	2.50		
PMA10013-Ax		PPM10605		Standard NEEDLE (Coated in "Cr")	14.00	2.00	24.00
PMA10014-Ax		PPM10606			14.00	2.50	
PMA10015-Ax		PPM10607			18.00	2.00	
PMA10016-Ax		PPM10608			18.00	2.50	
PMA10001-A	PDF10702	PPM10601	Standard NEEDLE (Coated in "Cr")	14.00	2.00	6.00	
PMA10002-A		PPM10602		14.00	2.50		
PMA10003-A		PPM10603		18.00	2.00		
PMA10004-A		PPM10604		18.00	2.50		
PMA10005-Ax		PPM10605		Standard NEEDLE (Coated in "Cr")	14.00	2.00	24.00
PMA10006-Ax		PPM10606			14.00	2.50	
PMA10007-Ax		PPM10607			18.00	2.00	
PMA10008-Ax		PPM10608			18.00	2.50	

Max. Torque
55 [N·m] / 405 Ft-Lbs
12 Point Deep Socket Req'd
17mm or 20mm

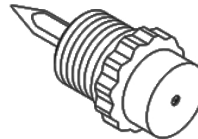

Open Nut Point Gate Tip

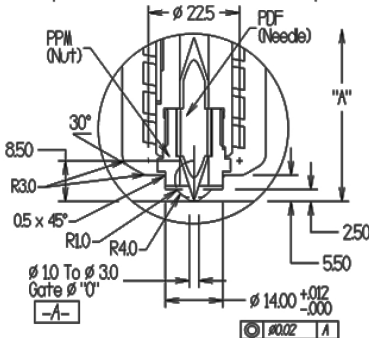

Open Nut Point Gate Tip

TP ASM #	Tip Components		
	NEEDLE	NUT	MATERIAL
PVM10002	PDF10502	PPM10609	Abrasion Resistant
PVM10001	PDF10702	PPM10609	Standard (Coated in "Cr")

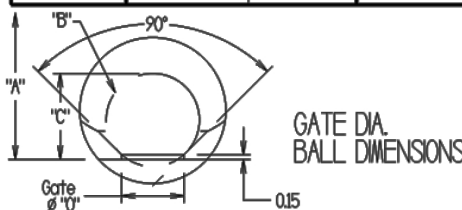

DIA. METER GATE	DIMENSION "B"	DIMENSION "C"
0.10		2.06
0.12	0.200	1.96
0.14		1.86
0.16		2.97
0.18	0.300	2.87
0.20		2.77
0.22		3.88
0.24	0.400	3.78
0.26		3.68
0.28		4.78
0.30	0.500	4.68

Max. Torque
45 [N·m] / 33 Ft - Lbs
12 Point Deep Socket Req'd
17mm



800 Series Standard Hot Sprue Bushing

Recommended for processing resins under 500°F

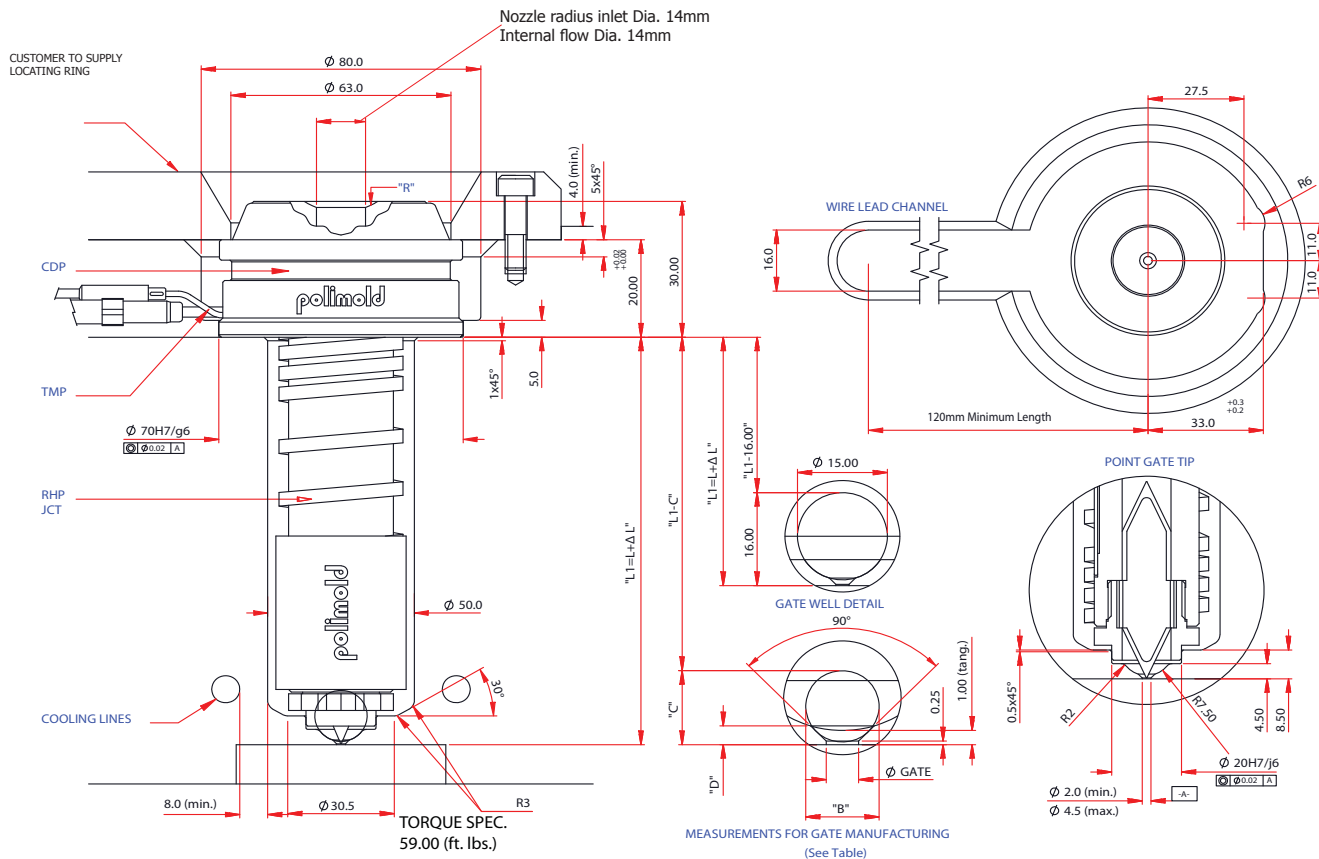

ASSEMBLY PART NUMBER	DIMENSION "L"	NOZZLE ASSEMBLY AND COMPONENT SPECIFICATIONS						
		NOZZLE BODY	NOZZLE BODY HEATER	JACKETS	HEATER REFLECTOR	NOZZLE BODY SPACER RING	WATTS	THERMOCOUPLE
HDP14075-R...	75.00	CDP14075	RHP14070	JCT14050	---	---	610W	TMP01100
HDP14100-R...	100.00	CDP14100	RHP14095	JCT14050	---	---	690W	TMP01140
HDP14125-R...	125.00	CDP14125	RHP14120	JCT14100	---	---	760W	TMP01160
HDP14150-R...	150.00	CDP14150	RHP14145	JCT14100	---	---	850W	TMP01180
HDP14175-R...	175.00	CDP14175	RHP14170	JCT14100	---	---	1100W	TMP01200
HDP14200-R...	200.00	CDP14200	RHP14195	JCT14051	TUBO14145	AEP14604	900W	TMP01220
HDP14225-R...	225.00	CDP14225	RHP14220	JCT14051	TUBO14170	AEP14604	900W	TMP01260
HDP14275-R...	275.00	CDP14275	RHP14270	JCT14051	TUBO14220	AEP14604	1100W	TMP01300

TABLE FOR GATE MANUFACTURING

GATE DIAMETER	DIMENSION		
	"B"	"C"	"D"
Ø 2.0	5.29	1.28	
Ø 2.2	5.19	1.32	
Ø 2.4	5.09	1.36	
Ø 2.6	4.99	1.42	
Ø 2.8	6.10	1.47	
Ø 3.0	6.00	1.53	
Ø 3.2	5.90	1.60	
Ø 3.4	5.80	1.68	
Ø 3.6	8.11	1.78	
Ø 3.8	8.01	1.88	
Ø 4.0	7.91	2.01	
Ø 4.5	7.66	2.49	

Ex: HDP14075-R075

(SPHERICAL RADIUS 3/4")

BUSHING THERMAL EXPANSION "Δ L" = L x 0.0000064 x (Setpoint °F - 68°F)

RADIUS CODE	DIMENSION "R"
...R050	1/2"
...R075	3/4"

TIP OPTIONS

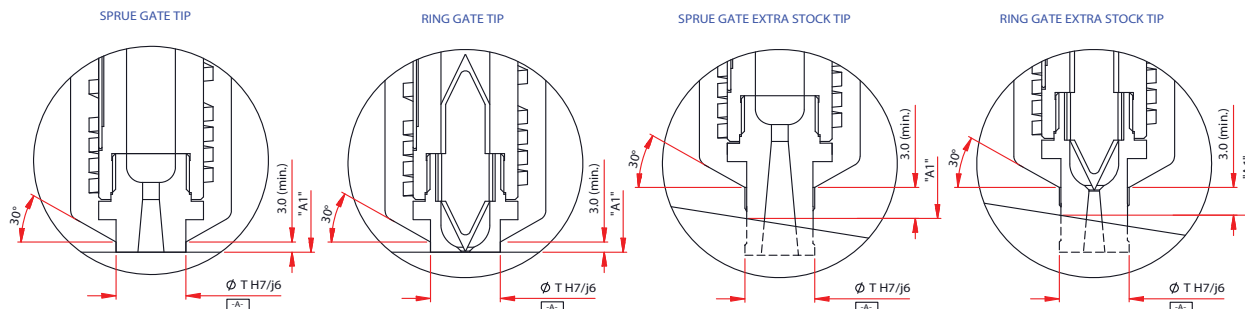

800 Series Standard Hot Sprue Bushing

NOTE: THIS HOT SPRUE BUSHING REQUIRES 2 ZONES OF CONTROL

Recommended for processing resins under 500°F

CUSTOMER TO SUPPLY
LOCATING RING

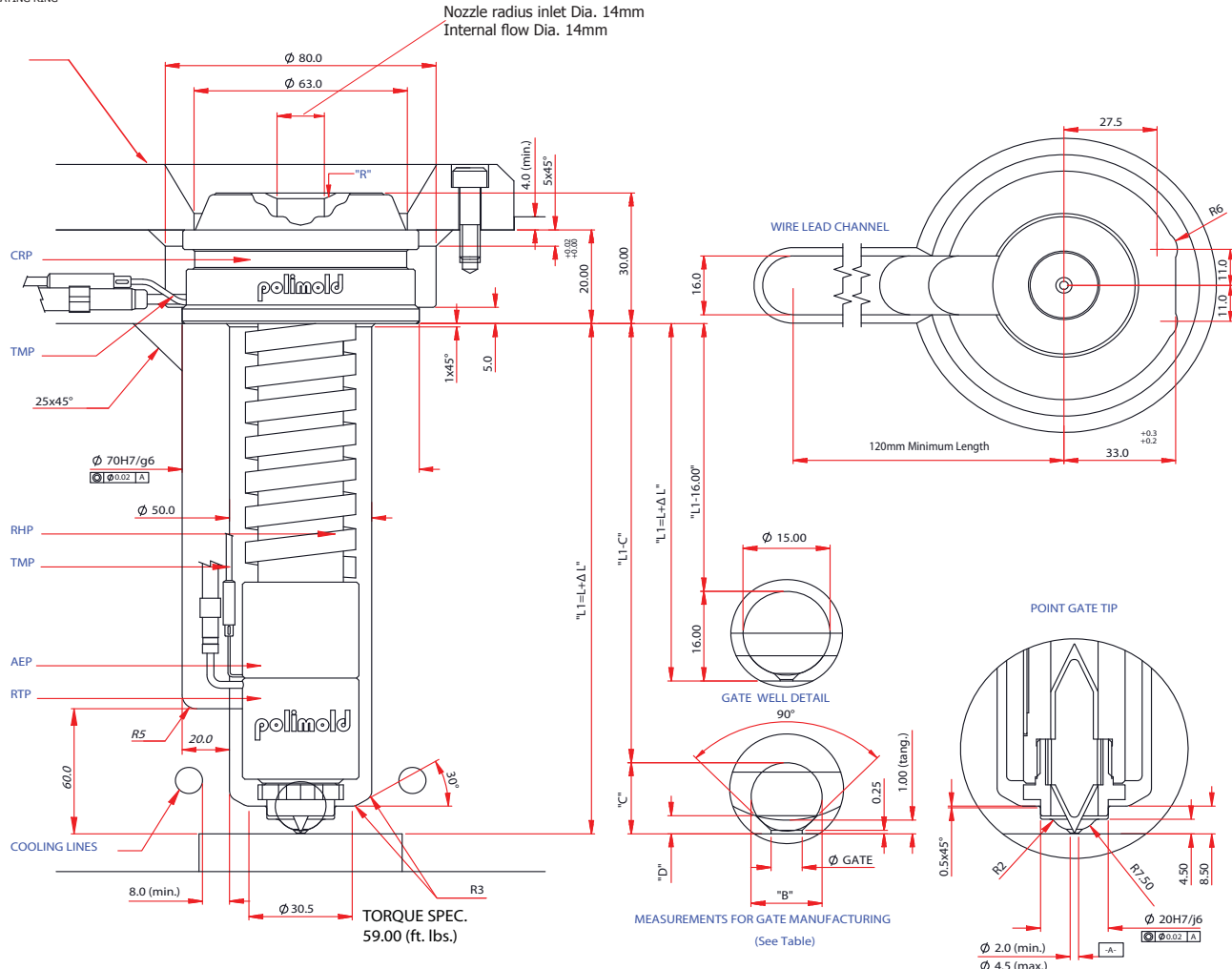

TABLE FOR GATE MANUFACTURING

NOZZLE ASSEMBLY AND COMPONENT SPECIFICATIONS										
ASSEMBLY PART NUMBER	DIMENSION "L"	COMPONENTS								
		NOZZLE BODY	NOZZLE BODY HEATER	HEATER REFLECTOR	WATTS	THERMOCOUPLE	LOWER NOZZLE BODY HEATER	WATTS	NOZZLE BODY SPACER RING	THERMOCOUPLE (Optional)
HDP14325-A-R...	325.00	CDP14325	RHP14220	TUBO14220	900W	TMP01220				
HDP14375-A-R...	375.00	CDP14375	RHP14270	TUBO14270	1100W	TMP01360				
HDP14425-A-R...	425.00	CDP14425	RHP14320	TUBO14320	1100W	TMP01400	RTP14045	610W	AEP14603	TMP01080
HDP14475-A-R...	475.00	CDP14475	RHP14370	TUBO14370	1100W	TMP01460				

GATE DIAMETER	DIMENSION		
	"B"	"C"	"D"
Ø 2.0		5.29	1.28
Ø 2.2		5.19	1.32
Ø 2.4	Ø 5.00	5.09	1.36
Ø 2.6		4.99	1.42
Ø 2.8		6.10	1.47
Ø 3.0		6.00	1.53
Ø 3.2	Ø 6.00	5.90	1.60
Ø 3.4		5.80	1.68
Ø 3.6		8.11	1.78
Ø 3.8		8.01	1.88
Ø 4.0	Ø 8.00	7.91	2.01
Ø 4.5		7.66	2.49

Ex: HDP14075-R075

BUSHING THERMAL EXPANSION "Δ L" = L x 0.0000064 x (Setpoint °F - 68°F)

(SPHERICAL RADIUS 3/4")

RADIUS CODE	DIMENSION "R"
...R050	1/2"
...R075	3/4"

TIP OPTIONS

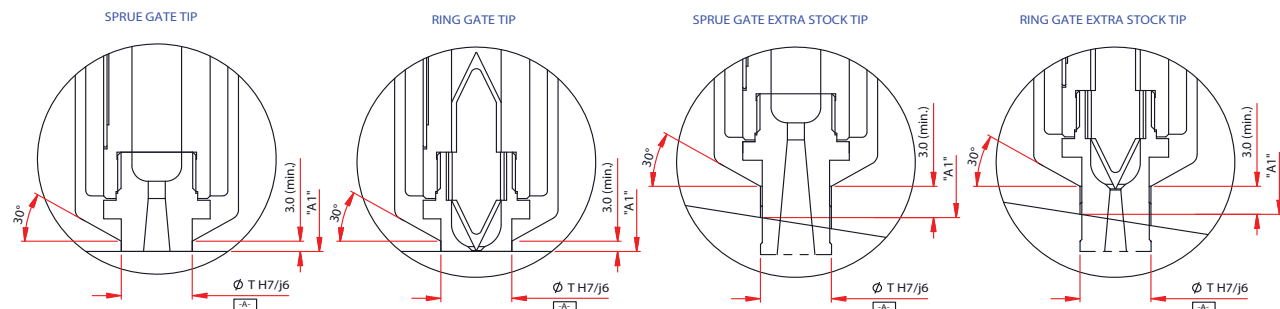

800 Series High Performance Hot Sprue Bushing

Recommended for processing resins over 500°F

NOTE: THIS HOT SPRUE BUSHING REQUIRES 2 ZONES OF CONTROL

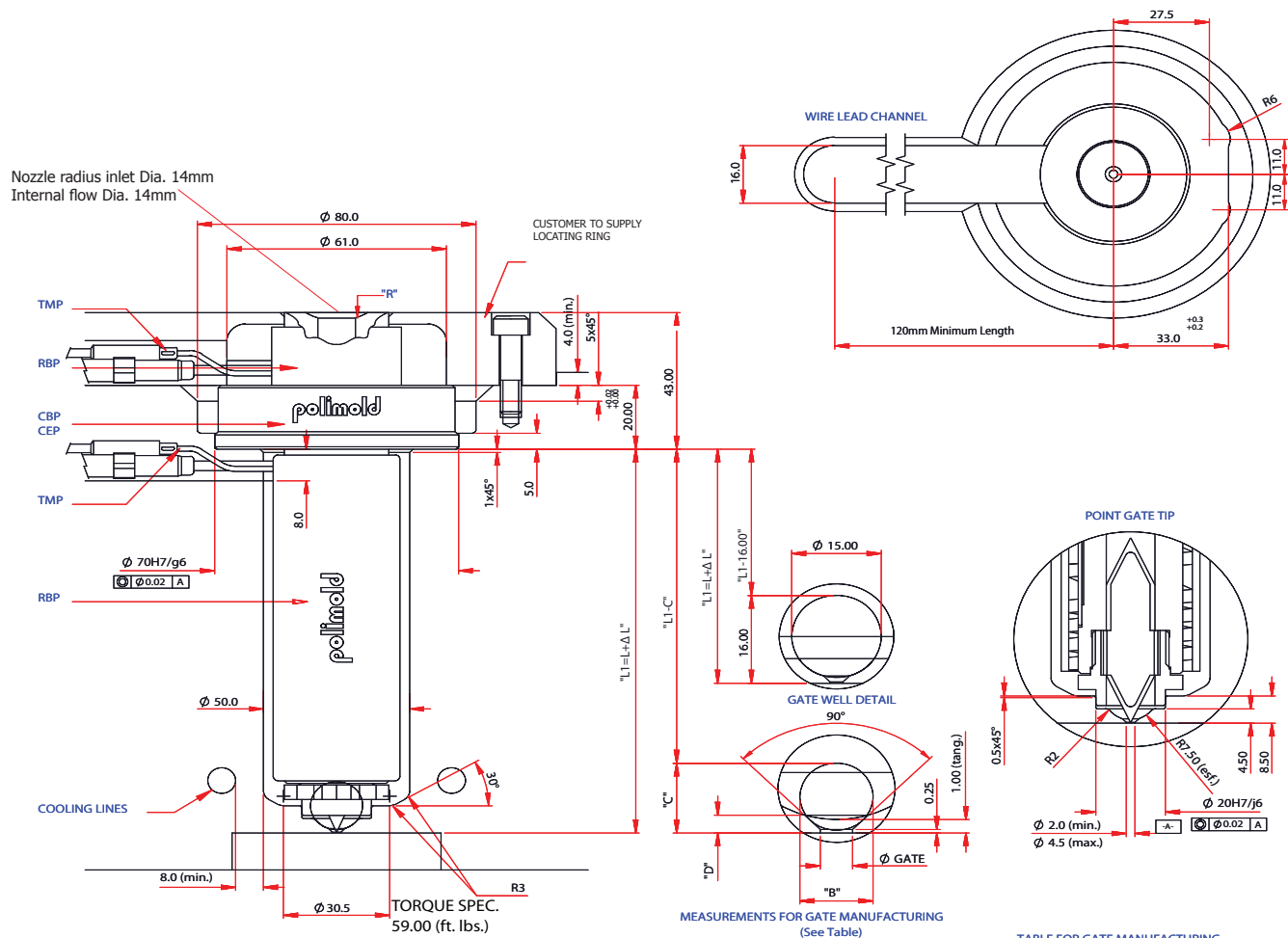

NOZZLE ASSEMBLY AND COMPONENT SPECIFICATIONS								
ASSEMBLY PART NUMBER	DIMENSION "L"	COMPONENTS						
		NOZZLE BODY	HEAD BUSHING	NOZZLE BODY HEATER	WATTS	THERMOCOUPLE	HEAD HEATER	WATTS
EDP14090-R...	90.00	CEP14090	CBP14001	RBP14070	850W	TMP01100	RBP14020	260W
EDP14115-R...	115.00	CEP14115		RBP14095	1100W	TMP01140		
EDP14140-R...	140.00	CEP14140		RBP14120	1100W	TMP01160		
EDP14165-R...	165.00	CEP14165		RBP14145	1300W	TMP01180		
EDP14190-R...	190.00	CEP14190		RBP14170	1300W	TMP01200		

Ex: EDP14090-R075

(SPHERICAL RADIUS 3/4")

BUSHING THERMAL EXPANSION "Δ L" = L x 0.0000064 x (Setpoint °F - 68°F)

TABLE FOR GATE MANUFACTURING

GATE DIAMETER	DIMENSION		
	"B"	"C"	"D"
Ø 2.0	Ø 5.00	5.29	1.28
Ø 2.2		5.19	1.32
Ø 2.4		5.09	1.36
Ø 2.6		4.99	1.42
Ø 2.8	Ø 6.00	6.10	1.47
Ø 3.0		6.00	1.53
Ø 3.2		5.90	1.60
Ø 3.4		5.80	1.68
Ø 3.6	Ø 8.00	8.11	1.78
Ø 3.8		8.01	1.88
Ø 4.0		7.91	2.01
Ø 4.5		7.66	2.49

RADIUS CODE	DIMENSION "R"
...-R050	1/2"
...-R075	3/4"

TIP OPTIONS

SPRUE GATE TIP

RING GATE TIP

SPRUE GATE EXTRA STOCK TIP

RING GATE EXTRA STOCK TIP

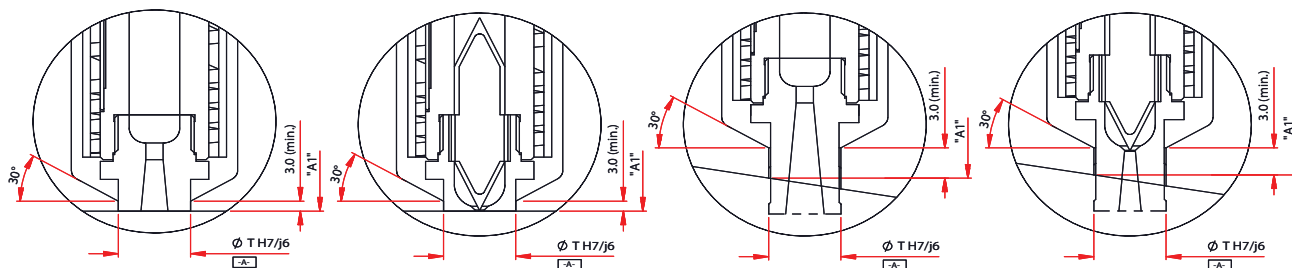

800 Series High Performance Hot Sprue Bushing

Recommended for processing resins over 500°F

NOTE: THIS HOT SPRUE BUSHING REQUIRES 4 ZONES OF CONTROL

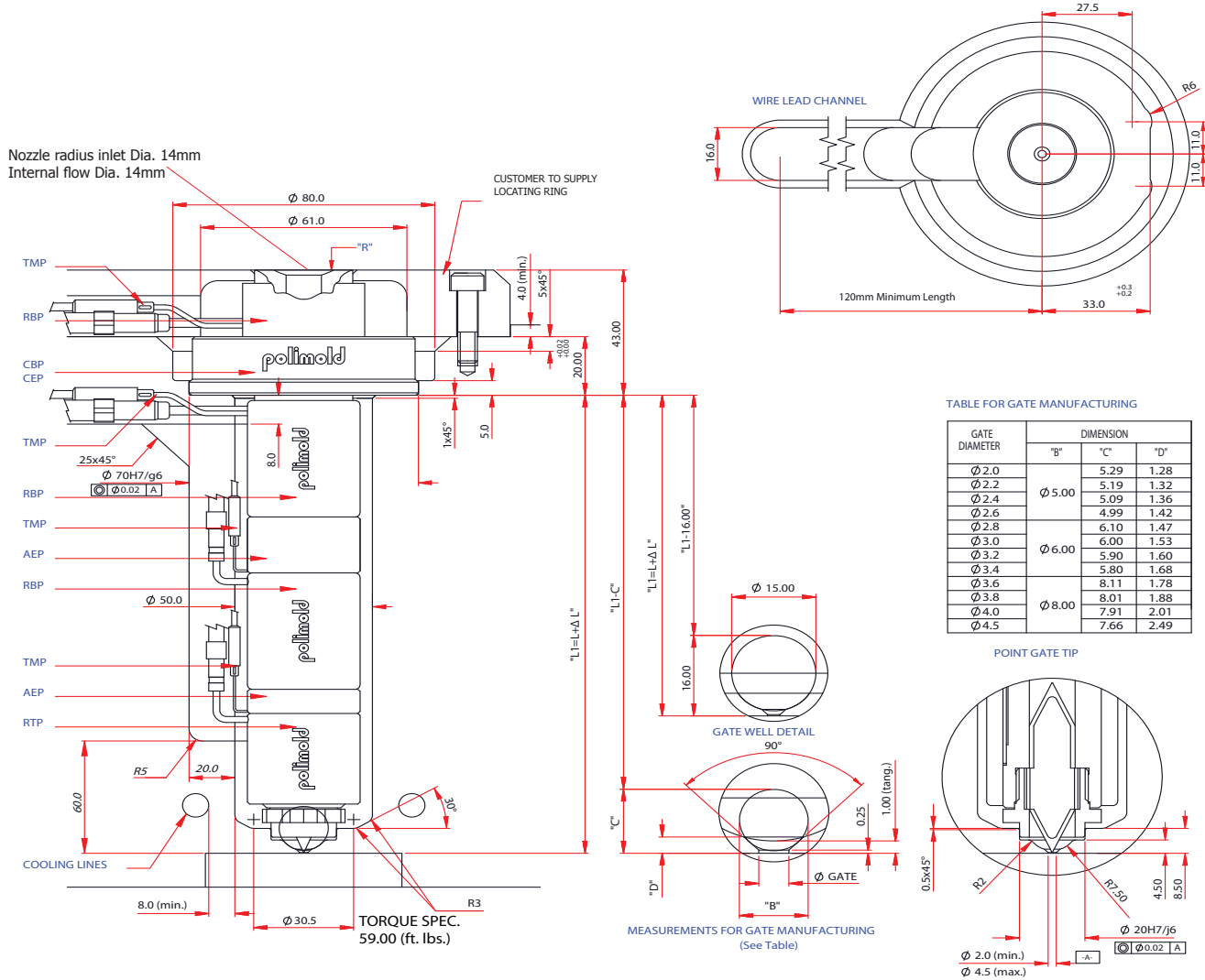
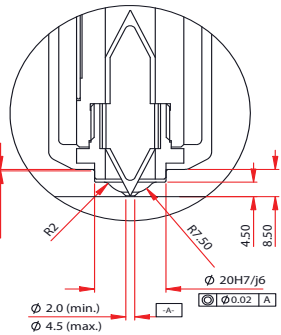

TABLE FOR GATE MANUFACTURING

GATE DIAMETER	DIMENSION		
	"B"	"C"	"D"
Ø 2.0	5.29	1.28	
Ø 2.2	5.19	1.32	
Ø 2.4	5.09	1.36	
Ø 2.6	4.99	1.42	
Ø 2.8	6.10	1.47	
Ø 3.0	6.00	1.53	
Ø 3.2	5.90	1.60	
Ø 3.4	5.80	1.68	
Ø 3.6	8.11	1.78	
Ø 3.8	8.01	1.88	
Ø 4.0	7.91	2.01	
Ø 4.5	7.66	2.49	

POINT GATE TIP



MEASUREMENTS FOR GATE MANUFACTURING (See Table)

NOZZLE ASSEMBLY AND COMPONENT SPECIFICATIONS															
ASSEMBLY PART NUMBER	DIMENSION "L"	NOZZLE BODY	HEAD BUSHING	NOZZLE BODY HEATER				QUANTITY	COMPONENTS						
				HEATER WATTS	THERMOCOUPLE	HEAD RING SPACER	HEAD HEATER		WATTS	HEATER REFLECTOR	WATTS	RING SPACER	THERMOCOUPLE		
EDP14350-R...	350.00	CEP14350	CBP14001	RBP14120	1100W	TMP01160	02	AEP14602	RBP14020	260W	RTP14045	610W	AEP14601	TMP01080	
EDP14400-R...	400.00	CEP14400		RBP14145	1300W	TMP01180									
EDP14450-R...	450.00	CEP14450		RBP14170	1300W	TMP01200									

Ex: EDP14350-R075

(SPHERICAL RADIUS 3/4")

RADIUS CODE	DIMENSION "R"
...R050	1/2"
...R075	3/4"

BUSHING THERMAL EXPANSION "Δ L" = L x 0.000064 x (Setpoint °F - 68°F)

TIP OPTIONS

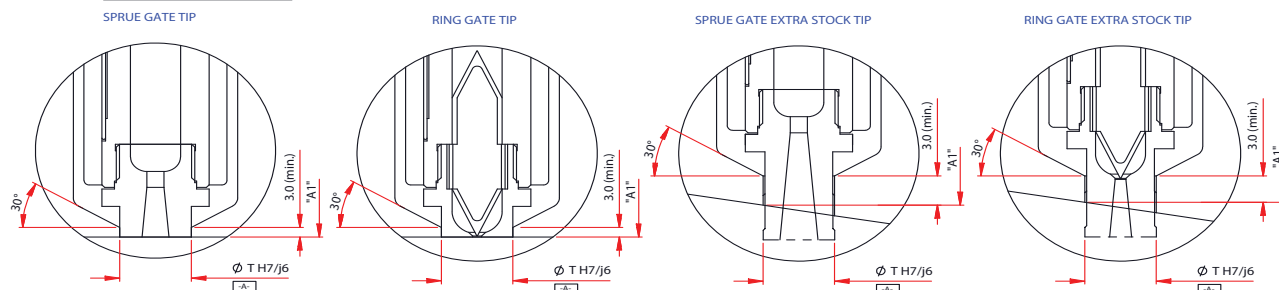

800 Series Tips

SPRUE GATE TIP (*Extended Tip Length)

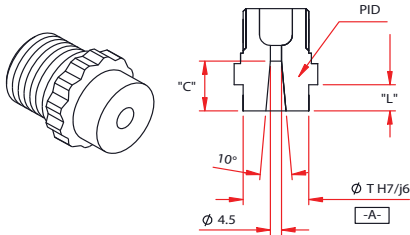

TIP DIMENSIONS			
PART NUMBER	DIMENSION "T"	DIMENSION "L"	DIMENSION "C"
PID14001	20.00	9.00	13.00
PID14002	30.00	9.00	13.00
PID14003	20.00	27.50	31.00*
PID14004	30.00	27.50	31.00*

1" T Dimension available upon request

RING GATE TIP (*Extend Tip Length)

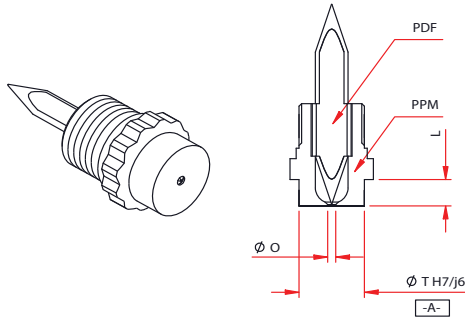

ASSEMBLY	ASSEMBLY COMPONENTS		MATERIAL	DIMENSION			
	NEEDLE	RETAINER TIP		"T"	"O"	"L"	
PMA14009-A	PDF14502	PPM14601	HIGH PERFORMANCE	20.00	2.50	9.00	
PMA14010-A		PPM14602		20.00	3.00		
PMA14011-A		PPM14603		30.00	2.50		
PMA14012-A		PPM14604		30.00	3.00		
PMA14013-A		PPM14605		PPM14606	20.00	2.50	27.50*
PMA14014-A		PPM14606		20.00	3.00		
PMA14015-A		PPM14607		30.00	2.50		
PMA14016-A		PPM14608		30.00	3.00		
PMA14109-A	PDF14802	PPM14601	STANDARD NEEDLE (COATED IN "Ni")	20.00	2.50	9.00	
PMA14110-A		PPM14602		20.00	3.00		
PMA14111-A		PPM14603		30.00	2.50		
PMA14112-A		PPM14604		30.00	3.00		
PMA14113-A		PPM14605		PPM14606	20.00	2.50	27.50*
PMA14114-A		PPM14606		20.00	3.00		
PMA14115-A		PPM14607		30.00	2.50		
PMA14116-A		PPM14608		30.00	3.00		

TORQUE SPECIFICATION

80 Nm
(59 Ft/Lbs)

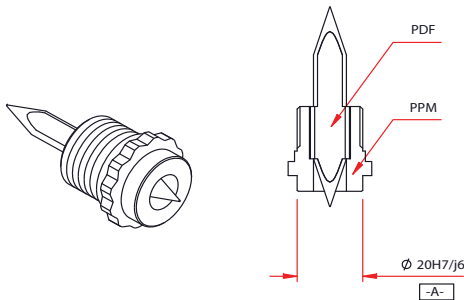

POINT GATE TIP

ASSEMBLY	POINT GATE COMPONENTS		
	NEEDLE	RETAINER	MATERIAL
PVM14002-A	PDF14502	PPM14609	HIGH PERFORMANCE NEEDLE
PVM14009-A	PDF14802	PPM14609	STANDARD NEEDLE (COATED IN "Ni")

Injection Molding Troubleshooting Guide

Recommended Solutions	PROBLEMS																			
	Nozzle Drool	Short Shot	Screw Does Not Return	Sink Marks	Burning	Blemishes	Flashing	Dull Surface	Part Lamination	Sticking Parts	Runner Breaks	Distortion	Discoloration of Sprue	Flow Lines	Brittle Parts	Wavy Surfaces	Melt Temp. Too High	Streaks On Part	Voids in Part	
Increase injection pressure		•										•		•						
Decrease injection pressure							•					•								
Increase resin temperature		•				•		•				•		•	•	•			•	
Decrease resin temperature					•		•			•			•			•	•			•
Increase holding pressure and time				•									•			•				
Increase nozzle temperature		•		•		•			•											•
Increase screw r.p.m.			•	•		•			•						•					
Decrease screw r.p.m.																	•	•		
Tighten nozzle tip													•						•	
Inject with rotating screw		•		•		•			•				•	•						
Increase clamping pressure							•													
Start injection speed	•																			
Decrease injection speed				•	•	•	•	•	•	•		•	•		•	•			•	•
Increase injection speed		•										•		•						
Increase back pressure		•		•		•			•				•	•					•	
Decrease back pressure			•	•													•			
Increase nozzle orifice		•	•	•			•	•				•	•			•				
Increase mold temperature		•				•		•	•	•		•	•	•	•					•
Decrease mold temperature				•		•	•	•		•	•	•			•	•	•			•
Polish sprue, runners and gates						•				•										
Increase size of gates		•		•	•	•		•	•				•	•	•					•
Check for proper venting		•			•									•						
Enlarge cold slug well						•					•		•							
Ensure dry material when required			•	•		•		•		•				•	•				•	
Check for resin contamination								•	•											
Increase shot size		•		•										•		•				•
Use mold release NanoMoldCoating™										•										
Adjust nozzle pressure	•																			
Check radius of nozzle & of sprue bushing	•								•	•										
Reduce temperature-rear zone			•																	
Balance mold filling, rework runners				•																
Provide air for ejection										•										
Lengthen cooling and mold-open time											•	•				•			•	
Shorten cooling and mold-open time																	•			

Resin Material Processing Guide

MATERIAL	SYMBOL	PROCESS TEMPERATURE		MOLD TEMPERATURE		HOT RUNNER TEMPERATURE		MELTING DENSITY		SOLID DENSITY	
		°C	°F	°C	°F	°C	°F	g/cm3	lbs./in3	g/cm3	lbs./in3
Polybutylene Terephthalate	PBT	265	509	60	140	290	554	1.44	0.052	1.570	0.057
Polycarbonate	PC	300	572	80	176	330	626	1.08	0.039	1.200	0.043
Polyether-etherketone	PEEK	330	626	165	329	370	698	1.13	0.041	1.370	0.050
Polymethyl Methacrylate	PMMA	235	455	70	158	250	482	1.09	0.039	1.180	0.043
Styrene Butadiene	SB	210	410	70	158	230	446	0.93	0.037	1.020	0.037
Acrylonitrile Butadiene Styrene	ABS	225	437	70	158	250	482	0.95	0.034	1.080	0.039
Polyvinyl chloride	FPVC	175	347	35	95	200	392	1.02	0.041	1.380	0.050
Polyoxymethylene (Ployacetal)	POM	180	356	100	212	200	392	1.16	0.042	1.420	0.051
Polypropylene	PP	225	437	40	104	245	473	0.73	0.027	0.910	0.033
Polyphenylene Oxide-Styrene	PPO	260	500	80	176	300	572	0.99	0.036	1.130	0.041
Polyphenylene Sulfide	PPS	300	572	110	230	330	626	1.53	0.055	1.700	0.061
Polystyrene	PS	210	410	45	113	230	446	0.95	0.034	1.050	0.038
Styrene-acrylonite	SAN	230	446	80	176	255	491	0.99	0.036	1.080	0.039
Polyamide 6	PA 6	220	428	90	194	250	482	0.98	0.035	1.140	0.041
Polyamide 66	PA66	255	491	90	194	280	536	1.09	0.039	1.260	0.046
Polyethylene	PE	200	392	25	77	225	437	0.74	0.027	0.960	0.035
Polyurethane	PUR	220	428	45	113	240	464	0.93	0.037	1.110	0.040
Thermal Plastic Elastomers	TPE	240	464	35	95	265	509	0.78	0.028	0.900	0.033

PLASTIC MATERIAL FLOW INDEX			
LOW MFI	MEDIUM MFI		HIGH MFI
PBT	ABS	PPS	PA 6
PC	FPVC	PS	PA66
PEEK	POM	SAN	PE
PMMA	PP		PUR
SB	PPO		TPE

NOTE:

The above temperatures and densities are general guidelines and may not apply to your current application. Refer to the resin manufacturers processing data guide for your current application

Decimal Equivalents & TAP Drill Sizes

DRILL SIZE	DECIMAL	TAP SIZE	DRILL SIZE	DECIMAL	TAP SIZE	DRILL SIZE	DECIMAL	TAP SIZE	DRILL SIZE	DECIMAL	TAP SIZE
80	0.014		39	0.100		A	0.234		37/64	0.578	
79	0.015		38	0.102	5-40	15/64	0.234		19/32	0.594	
1/64	0.016		37	0.104	5-44	B	0.238		39/64	0.609	
78	0.016		36	0.107	6-32	C	0.242		5/8	0.625	
77	0.018		7/64	0.109		D	0.246		41/64	0.641	
76	0.020		35	0.110		1/4	0.250		21/32	0.656	3/4-10
75	0.021		34	0.111		E			43/64	0.672	
74	0.023		33	0.113	6-40	F	0.257	5/16-18	11/16	0.688	3/4-16
73	0.024		32	0.116		G	0.261		45/64	0.703	
72	0.025		31	0.120		17/64	0.266		23/32	0.719	
71	0.026		1/8	0.125		H	0.266		47/64	0.734	
70	0.028		30	0.129		I	0.272	5/16-24	3/4	0.750	
69	0.029		29	0.136	8-32,36	J	0.277		49/64	0.766	7/8-9
68	0.031		28	0.141		K	0.281		25/32	0.781	
1/32	0.031		9/64	0.141		9/32	0.281		51/64	0.797	
67	0.032		27	0.144		L	0.290		13/16	0.813	7/8-14
66	0.033		26	0.147		M	0.295		53/64	0.828	
65	0.035		25	0.150	10-24	19/64	0.297		27/32	0.844	
64	0.036		24	0.152		N	0.302		55/64	0.859	
63	0.037		23	0.154		5/16	0.313	3/8-16	7/8	0.875	1-8
62	0.038		5/32	0.156		O	0.316		57/64	0.891	
61	0.039		22	0.157		P	0.323		29/32	0.906	
60	0.040		21	0.159	10-32	21/64	0.328		59/64	0.922	1-12
59	0.041		20	0.161		Q	0.332	3/8-24	15/16	0.938	
58	0.042		19	0.166		R	0.339		61/64	0.953	
57	0.043		18	0.170		S	0.348		31/32	0.969	
56	0.047		11/64	0.172		T	0.358		63/64	0.984	1 1/8-7
3/64	0.047	0-80	17	0.173		23/64	0.359		1"	1.000	
55	0.052		16	0.177	12-24	U	0.368	7/16-14	1 3/64	1.047	1 1/8-12
54	0.055		15	0.180		3/8	0.375		1 7/64	1.109	1 1/4-7
53	0.060	1-64,72	14	0.182	12-28	V	0.377		1 1/8	1.125	
1/16	0.063		13	0.185		W	0.386		1 11/64	1.172	1 1/4-12
52	0.064		3/16	0.188		25/64	0.391	7/16-20	1 7/32	1.219	1 3/8-6
51	0.067		12	0.189		X	0.397		1 1/4	1.250	
50	0.070	2-56,64	11	0.191		Y	0.404		1 19/64	1.297	1 3/8-12
49	0.073		10	0.194		13/32	0.406		1 11/32	1.344	1 1/2-6
48	0.076		9	0.196		Z	0.413		1 3/8	1.375	
5/64	0.078		8	0.199		27/64	0.422	1/2-13	1 27/64	1.422	1 1/2-12
47	0.079	3-48	7	0.201	1/4-20	7/16	0.438		1 1/2	1.500	
46	0.081		13/64	0.203		29/64	0.453	1/2-20			
45	0.082	3-56	6	0.204		15/32	0.469				
44	0.086		5	0.206		31/64	0.484	9/16-12			
43	0.089	4-40	4	0.209		1/2	0.500				
42	0.094	4-48	3	0.213	1/4-28	33/64	0.516	9/16-18			
3/32	0.094		7/32	0.219		17/32	0.531	5/8-11			
41	0.096		2	0.221		35/64	0.547				
40	0.098		1	0.228		9/16	0.563				

Ohms Law
 240 V = 15 Amps = 3600 W
 Volts x Amps = Watts
 Watts / Volts = Amps
 Watts / Amps = Volts

PIPE THREAD SIZES			
DRILL	THREAD	DRILL	THREAD
R	1/8-27	1 5/32	1"-11 1/2
7/16	1/4-18	1 1/2	1 1/4-11 1/2
37/64	3/8-18	1 47/64	1 1/2-11 1/2
23/32	1/2-14	2 7/32	2"-11 1/2
59/64	3/4-14		

CONVERSION CHART		
1 INCH = 25.4mm	1 PSI = .0689 BAR	1 Metric Ton = 2204.6lbs=1000Kg
1 LBS = 453.59 g	1 mile = 1.609Klm	1 long Ton = 2240lbs=1016Kg
1 Oz = 28.349g	1 Ft = .3048M	1 short Ton = 2000lbs=907.18Kg
Temp (T° f-32°÷1.8 =T° c)	1 Ft/LBS = 1.356Nm	1 US Gal=.833 Imp Gal=3.785L
1 BTU = .0002929 Kw	Area of circle = n R ²	SAE Bolt rating =#(0-1-2) weakest to
1 Horse Power = 746 Watts	Circumference = 2 n r	#8 strongest

Wattage/Amperage/Resistance Chart

WATTS	AMPS	OHMS	WATTS	AMPS	OHMS	WATTS	AMPS	OHMS
50	0.21	1152.00	1850	7.71	31.14	4800	20.00	12.00
100	0.42	576.00	1900	7.92	30.32	4900	20.42	11.76
150	0.63	384.00	1950	8.13	29.54	5000	20.83	11.52
200	0.83	288.00	2000	8.33	28.80	5100	21.25	11.29
250	1.04	230.40	2050	8.54	28.10	5200	21.67	11.08
300	1.25	192.00	2100	8.75	27.43	5300	22.08	10.87
350	1.46	164.57	2150	8.96	26.79	5400	22.50	10.67
400	1.67	144.00	2200	9.17	26.18	5500	22.92	10.47
450	1.88	128.00	2250	9.38	25.60	5600	23.33	10.29
500	2.08	115.20	2300	9.58	25.04	5700	23.75	10.11
550	2.29	104.73	2350	9.79	24.51	5800	24.17	9.93
600	2.50	96.00	2400	10.00	24.00	5900	24.58	9.76
650	2.71	88.62	2450	10.21	23.51	6000	25.00	9.60
700	2.92	82.29	2500	10.42	23.04	6100	25.42	9.44
750	3.13	76.80	2600	10.83	22.15	6200	25.83	9.29
800	3.33	72.00	2700	11.25	21.33	6300	26.25	9.14
850	3.54	67.76	2800	11.67	20.57	6400	26.67	9.00
900	3.75	64.00	2900	12.08	19.86	6500	27.08	8.86
950	3.96	60.63	3000	12.50	19.20	6600	27.50	8.73
1000	4.17	57.60	3100	12.92	18.58	6700	27.92	8.60
1050	4.38	54.86	3200	13.33	18.00	6800	28.33	8.47
1100	4.58	52.36	3300	13.75	17.45	6900	28.75	8.35
1150	4.79	50.09	3400	14.17	16.94	7000	29.17	8.23
1200	5.00	48.00	3500	14.58	16.46	7100	29.58	8.11
1250	5.21	46.08	3600	15.00	16.00	7200	30.00	8.00
1300	5.42	44.31	3700	15.42	15.57	7300	30.42	7.89
1350	5.63	42.37	3800	15.83	15.16	7400	30.83	7.78
1400	5.83	41.14	3900	16.25	14.77	7500	31.25	7.68
1450	6.04	39.72	4000	16.67	14.40	7600	31.67	7.58
1500	6.25	38.40	4100	17.08	14.05	7700	32.09	7.48
1550	6.46	37.16	4200	17.50	13.71	7800	32.50	7.38
1600	6.67	36.00	4300	17.92	13.40	7900	32.92	7.29
1650	6.88	34.91	4400	18.33	13.09	8000	33.33	7.20
1700	7.08	33.88	4500	18.75	12.80	8100	33.75	7.11
1750	7.29	32.91	4600	19.17	12.52	8200	34.17	7.02
1800	7.50	32.00	4700	19.58	12.26	8300	34.58	6.94

Note: This chart is based on a Voltage of 240 VAC