



ONYX

USER MANUAL

TC1200 / TC2400 / TC3600

Multi-Cavity Hot Runner Temperature Controller





Please read through this user manual carefully before operating the TC1200 / TC2400 / TC3600 to avoid damage to machinery or injury to personnel from improper operation. The controller should also be placed in a well-ventilated area to ensure the stability of the instrumentation.

Table of Contents

Chapter I	Safety Precautions	3
Chapter II	Features	5
Chapter III	Appearance and Electronic Control System	
3.1	Appearance (dimensions, components)	6
3.2	Electronic Layout	8
3.3	Temperature Control Module (TC52-MDL)	9
3.4	Bus Board (TC52-BUS)	11
3.5	Alarm Board (TC52-ALM)	11
3.6	Overvoltage Protection Board (TC52-OVP)	12
3.7	BUS board on Top (TC52-BUS-T)	12
3.8	Power Supply and Overvoltage Protection	13
Chapter IV	Convenient Functions	
4.1	Mold Self-Diagnostics	15
4.2	Thermocouple LB Behavior (Manual and Slave)	15
4.3	Synchronous Heating / Timing Warming	16
4.4	Synchronous Cooling	17
Chapter V	Precautions	
5.1	Connection between controller & Mold	18
5.2	Basic Parameter Setup	18



Please read through this user manual carefully before operating the TC1200 / TC2400 / TC3600 to avoid damage to machinery or injury to personnel from improper operation. The controller should also be placed in a well-ventilated area to ensure the stability of the instrumentation.

Chapter VI HMI Instructions

6.1	Monitor.....	19
6.2	Zone Parameter Setup.....	29
6.3	System Setup	35
6.4	Mold Maintenance	38
6.5	Curve Record.....	49
6.6	Press Alarm Feature.....	50
6.7	Alarm Record.....	55

Chapter VII Troubleshooting..... 56

Chapter VIII Connector Wiring

8.1	Connection type A	57
8.2	Connection type B	57
8.3	Connection type C	57

Chapter I Safety Precautions

To ensure the safe and effective operation of the TC1200 / TC2400 / TC3600 Multi-Cavity Hot Runner Temperature Control System, please read through this user manual carefully before operating the TC1200 / TC2400 / TC3600 and follow the warnings and instructions provided.

Precautions before use:

1. Must be installed on a flat, stable floor in a well-ventilated area. Avoid humid, dusty or high-temperature environments. Installation in the above environments increases the risk of equipment failure or malfunctions and may even cause a fire.
2. Pay attention to the type of power supply, voltage and power capacity before connecting the TC1200 / TC2400 / TC3600 to the power supply. Using a power supply that does not meet specifications will cause serious system damage. When the master power switch is turned on, if the Over Voltage Source (OVS) light comes on it means the power supply's voltage is too high ($\geq 280\text{Vac}$). The main power switch must be turned off at once and the power distribution verified.
3. Before turning on the main power switch for the TC1200 / TC2400 / TC3600, make sure that the system ground (FG) is properly connected. Improper grounding may lead to electrocution of personnel or damage to equipment.
4. Check that the TC1200 / TC2400 / TC3600 and mold cable connection type are compatible with each other before connecting the two. Incompatible connection type poses an electrocution hazard and will damage equipment.
5. Make sure that the TC1200 / TC2400 / TC3600 cooling fan is working at all times. A blockage will impact on heat dissipation so always keep the fan clean and running.
6. Do not attempt to modify or change this control system without proper training. Improper modifications may lead to electrocution, injury, equipment damage, fire and other hazards.

7. Immediately turn off the main power switch if there is any smoke, sparks, strange smells or odd noises during the operation of the TC1200 / TC2400 / TC3600 and have a technician conduct an inspection. Do not turn on the power again before the problem is resolved.
8. The TC1200 / TC2400 / TC3600 may only be maintained by trained personnel. The main power switch must be turned off before maintenance. Disassembling the TC1200 / TC2400 / TC3600 while the power is connected poses serious electrocution hazard.
9. Storage Temperature: -20~70°C / -4~158°F
Operating Temperature: -10~50°C / 14~122°F
Operating Humidity: 0~80%RH (non-condensing)

Chapter II Features

1. The power configuration is simple and easy to change, making it compatible with most electrical systems around the world.
2. Heater detection function (voltage, current, resistance and power rating) allows monitoring of heater status.
3. Multiple types of module anomaly detection for quick troubleshooting.
4. Simple and easy to use HMI interface.
5. Mold self-diagnostics function that shortens maintenance time by quickly identifying problems with the control module and molds.
6. Thermocouple break that can be set to manual or slave mode to keep production going.
7. Synchronous heating function to avoid power being tripped by excessive loading. This also prevents residue in the tip from becoming carbonized by high temperatures for extended periods of time and impacting product quality.
8. Shutdown, cooling and standby function for the tip to prevent tip deformation due to the tip and manifold cooling at different rates.
9. Triangulated control technology that dynamically balances three-phase power based on the load to lower power loss.

Chapter III Appearance and Electronic Control System

3.1 Appearance (dimensions, components)

Dimensions of TC3600, TC2400, TC1200 (36Z, 24Z, 12Z)

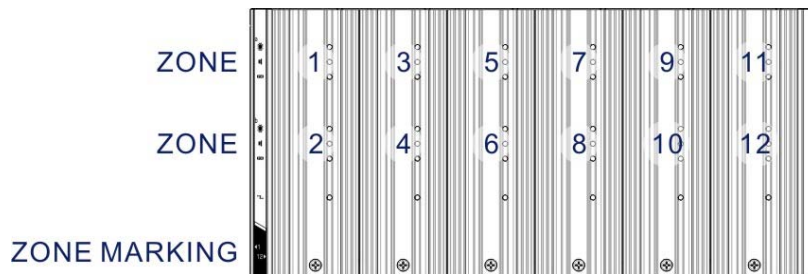
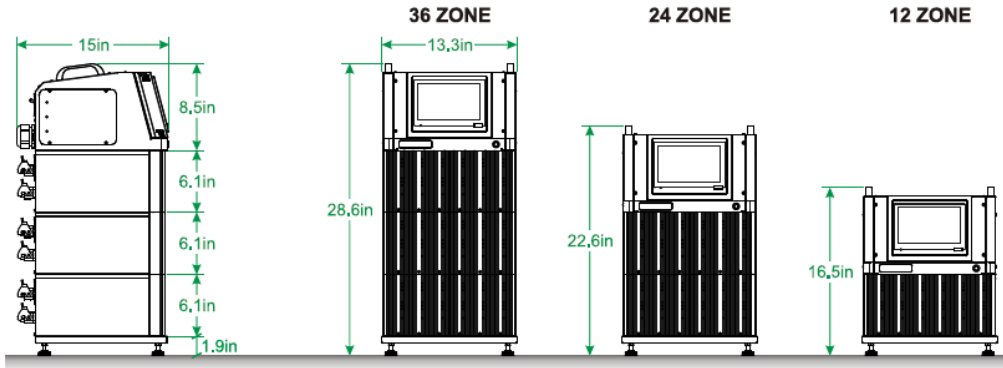

Layout of zones 1~12 shown above

TC2400 Components

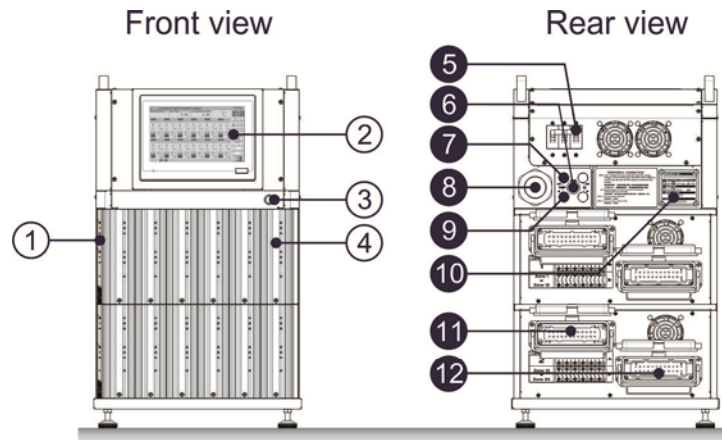

- ① Zone marking
- ② HMI
- ③ Power indicator
- ④ Temperature control module
- ⑤ Main power switch / NFB
- ⑥ Over-voltage / Phase lose source indicator (OVS)
- ⑦ Controller to controller communication port
- ⑧ Power cable
- ⑨ Press alarm communication port
- ⑩ Machine name plate
- ⑪ Mold power cable port
- ⑫ Mold thermocouple cable port

3.2 Electronic Layout

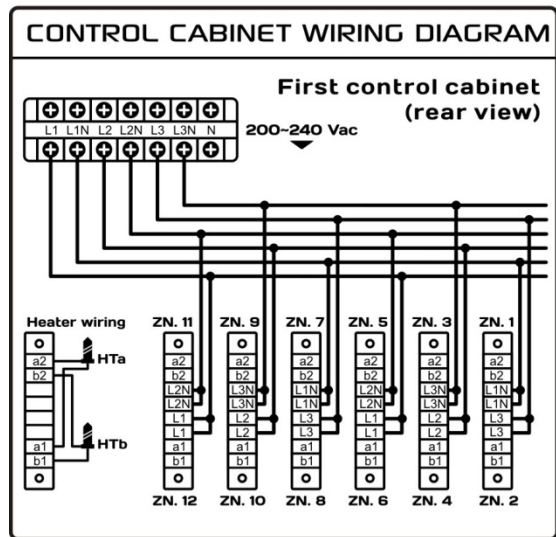
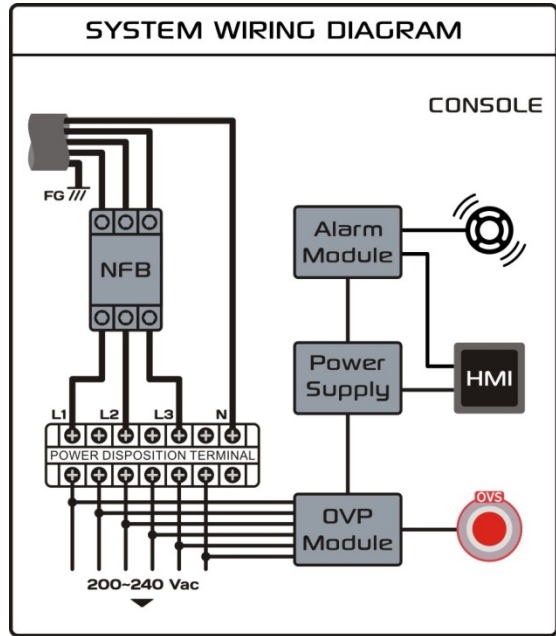

3.3 Temperature Control Module (TC52-MDL)

15A



1. Control Zone: 2 zones
2. Power Input: 230Vac \pm 10% / 24Vdc \pm 5%, 50/60Hz
3. Power Consumption: 230Vac: 3W / 24Vdc: 2W
4. Power Output: 3450W, 230Vac / 15A (per zone)
5. Thermocouple: J/K type
6. Temperature Control Range: 0~600°C / 32~999°F
7. Control Precision: \pm 0.25%FS
8. Measurement Precision: \pm 0.25%FS
9. Output Mode: Zero cross / Phase angle
10. Fuse: Ceramic 250Vac / 20A, 30mm
11. Detection Functions: Current / Voltage / Fuse Open Circuit / Heat sink temperature detection
12. Temperature Alarm Mode: Higher limit / Lower limit / Standby Higher limit / Standby lower limit / Absolute alarm
13. Fault Detection:
 - Thermocouple: Short / Break / Reverse
 - Heater: Short / Break / Overload
 - TRIAC: Short
 - Fuse Open Circuit
14. Communication Mode: RS-485 (Standard MODBUS, Isolated)
15. Communication Rate: 38400 / 57600
16. ID Setup: Automatic identification (requires compatible BUS board)
17. Indicator Lights: Output, Alarm, Fuse Open Circuit, Communication
18. Storage Temperature: -20~70°C / -4~158°F
19. Operating Temperature: -10~50°C / 14~122°F
20. Operating Humidity: 0~8%RH (No condensation)

3.4 Bus Board (TC52-BUS)



1. Power Input: 230Vac \pm 10% / 24Vdc \pm 5%
2. Power Frequency: 50/60Hz
3. Storage Temperature: -20~70°C / -4~158°F
4. Operating Temperature: -10~50°C / 14~122°F
5. Operating Humidity: 0~80%RH (No condensation)
6. ID Setup: DIP switch
- 7.

3.5 Alarm Board (TC52-ALM)

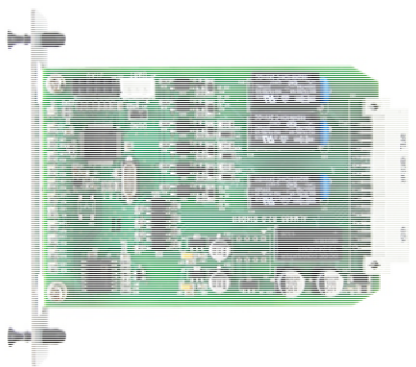

1. Power Input: 24Vdc \pm 5%
2. Communication Mode: RS-485 (Standard MODBUS, Isolated)
3. Storage Temperature: -20~70°C / -4~158°F
4. Operating Temperature: -10~50°C / 14~122°F
5. Operating Humidity: 0~80%RH (No condensation)
6. ID: 255, fixed
7. Communication Rate: 38400 / 57600
8. Output: 4 point; dry contact / 7A

3.6 Overvoltage Protection Board (TC52-OVP)

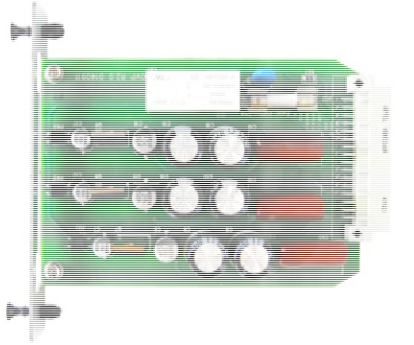

1. Power Input: 3 Φ , 230Vac \pm 10% (Phase lose protection)
2. Action Voltage: \geq 280Vac (Trigger overvoltage protection)
3. Storage Temperature: -20~70°C / -4~158°F
4. Operating Temperature: -10~50°C / 14~122°F
5. Operating Humidity: 0~80%RH (No condensation)
6. Output: 250Vac / 10A
7. Fuse: Ceramic 250Vac / 10A, 20mm
8. Overvoltage Indication (OVS): Indicator light output.

3.7 BUS board on Top (TC52-BUS-T)

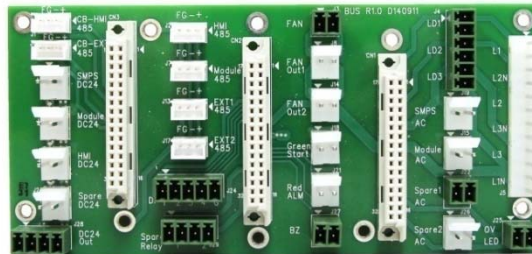

1. Power Input: 230Vac \pm 10% / 24Vdc \pm 5%
2. Power Frequency: 50/60Hz
3. Storage Temperature: -20~70°C / -4~158°F
4. Operating Temperature: -10~50°C / 14~122°F
5. Operating Humidity: 0~80%RH (No condensation)

3.8 Power Supply and Overvoltage Protection

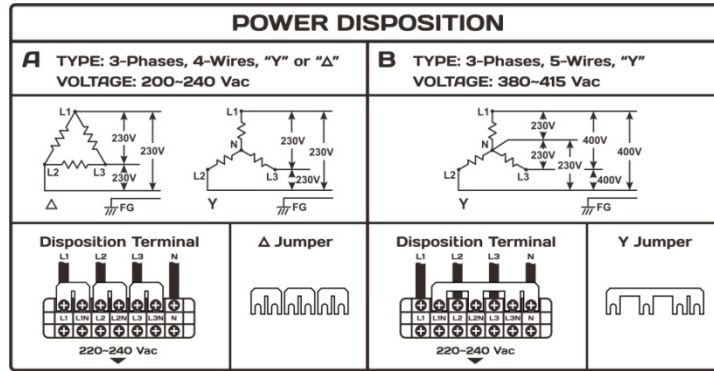

The TC1200 / TC2400 / TC3600 can be connected to 3-phase 4-wire Y/Δ type (230Vac) or 3-phase 5-wire Y type (400Vac) power supplies. Power disposition ensures that 230Vac is delivered to each layer in the control cabinet, allowing the user to adapt the power configuration to their requirements. The configuration must be carried out by trained technicians however.

TC1200 / TC2400 / TC3600 Y/Δ Wire Changing:

Remove the side panel to change the Y/Δ wiring, replacement jumpers are attached to the inside of the panel.

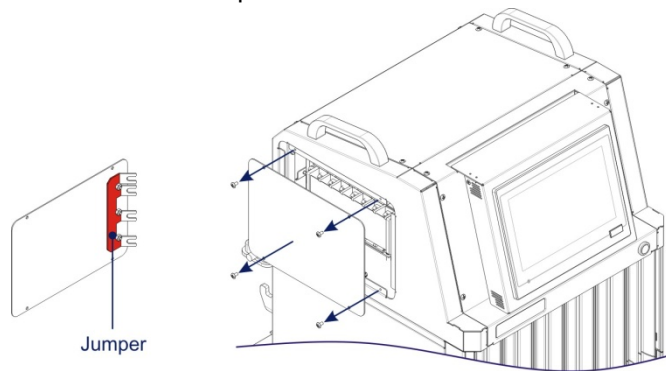

Y/Δ Wire Changing:

Remove the top cover and side panel in order, replacement jumpers are attached to the inside rack.

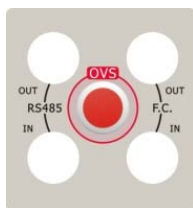
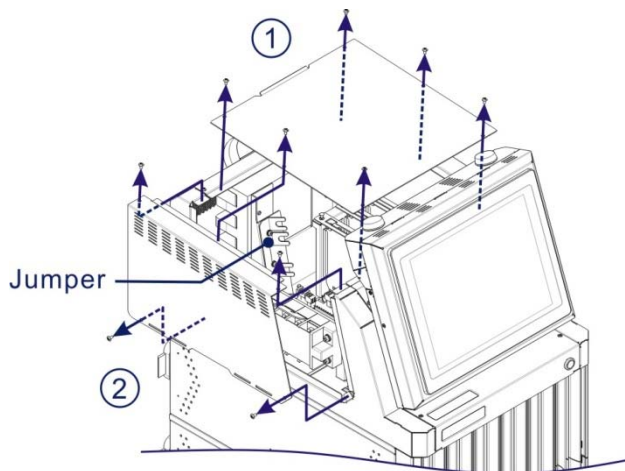

After main power is turned on to the TC1200 / TC2400 / TC3600, check the "Overvoltage Source (OVS)" light. If the OVS light remains constant, then the voltage delivered to the control cabinet at each layer exceeds 280Vac. In this situation, immediately turn off TC1200 / TC2400 / TC3600 main power then check the power input and power configuration again.

4.1 Mold Self-Diagnostics

Due to the complexity of multi-cavity molds, TC1200 / TC2400 / TC3600 offers convenient mold self-diagnostics functions to reduce trouble shooting. This diagnostics function provides the user with a simple way to troubleshoot most temperature controller and mold malfunctions.

- Module status: TRIAC / fuse
- Heater: Short / Break / Overload
- Mold Thermocouple: Wiring error

When the temperature control module detects a dangerous or anomalous situation, it automatically cuts the power output to prevent danger to personnel and equipment. (refer to 6.4-1-(5) P42 for details)

4.2 Thermocouple (Manual and Slave)

TC1200 / TC2400 / TC3600 offers two thermocouple break modes that allows production to continue and maintenance to be deferred until the end of the current production run (refer to 6.2-③-8 P31 for details):

- Manual: The user can pre-define the appropriate manual output percentages for each zone. If a thermocouple fails in one zone, TC1200 / TC2400 / TC3600 will automatically switch temperature control for that zone to manual so the heater will continue to maintain the production temperature and keep production running.

- **Slave:** Multi-cavity molds are mostly used for producing similar products. Molds for the same product use similar heaters and component structures as well so the production temperatures are quite similar as well. The user can identify mold cavities with similar production conditions and set up master-slave relationships in advance. If the thermocouple for a zone fails and a master-slave relationship had **previously been defined**, TC1200 / TC2400 / TC3600 will automatically transmit the output percentage from a zone with working temperature control to the zone with the failed thermocouple. This maintains more precise temperature control than manual mode for that zone and allows production to continue.

4.3 Synchronous Heating / Timing Warming

(Check that the heater for each zone matches the selected identification)

Multi-cavity molds have more heating components (tip, manifold, etc) so they consume more power. If the temperature controller is set for all of the zones to come on at once, the power consumption may be large enough to trip the breaker. There is also a relatively big difference between the heating time for tips and manifolds. When tips reach the set temperature, they will still need to wait for the manifolds to reach the set temperature before production can begin. The resin at the tip may be degraded by being exposed to high temperature for an extended period of time, impacting product quality or even resulting in tip blockages.

TC1200 / TC2400 / TC3600 is equipped with synchronous heating and timing warming function to solve the above problem. In this way, the problems with power outages and extended exposure of feed to high temperature are resolved.

Synchronous heating: When the manifold is being heated, a lower output percentage is maintained for the tip and this is slaved to the manifold temperature. Independent control is only resumed upon approaching the set temperature.

Timing Warming: Manifold heated to a set temperature, after tip warmed up to 70 degrees. When the Manifold heat reaches the set temperature, the tip is heated to a set temperature. Independent control is only resumed upon approaching the set temperature.

Refer to 6.3-2(3) P36 for setting.

"Synchronous Heating" or "Timing Warming" will be shown in the bottom of main menu when the function is enabled.

4.4 Synchronous Cooling

(Check that the heater for each zone matches the selected identification)

Some multi-cavity molds have very sophisticated tip construction. During shutdown and cooling, the tip will cool at a faster rate than manifolds. When the temperature difference becomes too great, the uneven temperature in the hot runner system can cause the tip to warp and in serious cases may even impact tip service life.

TC1200 / TC2400 / TC3600 offers a synchronous cooling function during shutdown. The system automatically keeps all heaters cooling at the same rate to reduce malfunctions caused by excessive temperature difference.

Refer to 6.3-2-(2) P36 for setting.

"Synchronous Cooling" and mode icon will be shown in the bottom of main menu when the function is enabled.

Chapter V

Precautions

5.1 Connection between TC1200 / TC2400 / TC3600 and Mold

To keep the entire multi-cavity hot runner system in working order, the user must perform the following checks before connecting the TC1200 / TC2400 / TC3600 with the mold:

1. Confirm that the operating environment is stable, non-humid, low-dust and at a suitable temperature.
2. Confirm that the power cable is not damaged and securely connected.
3. Confirm that the TC1200 / TC2400 / TC3600 and mold are properly grounded.
4. Check that the TC1200 / TC2400 / TC3600 main power switch is set to "OFF".
5. Confirm that the TC1200 / TC2400 / TC3600 and the mold are properly connected.
6. Confirm that the wiring between the TC1200 / TC2400 / TC3600 and mold are not damaged. Confirm connection type matches the way that TC1200 / TC2400 / TC3600 and the mold are connected.
7. Only when all of the above checks have been completed can the user connect the TC1200 / TC2400 / TC3600 and the mold, turn on the power and prepare to commence production.

5.2 Basic Parameter Setup

After turning on the power, please set the basic parameters as shown in 6.2 page 29~38.

1. Setting Value: The setting value (SV) for the current zone. Press to set.
2. TC Type: J/K type thermocouple
3. Heater Type: TIP / M.F. (Manifold)
4. Soft Start: Enable heater drying function.
5. Self Tune: Enable Self-tuning mode (Enable / Once / Always).
6. Output Mode: Z.C. (Zero cross) / P.A. (Phase angle)
7. LB Behavior: Stop / Manual / Slave (refer to 4.2 P14)







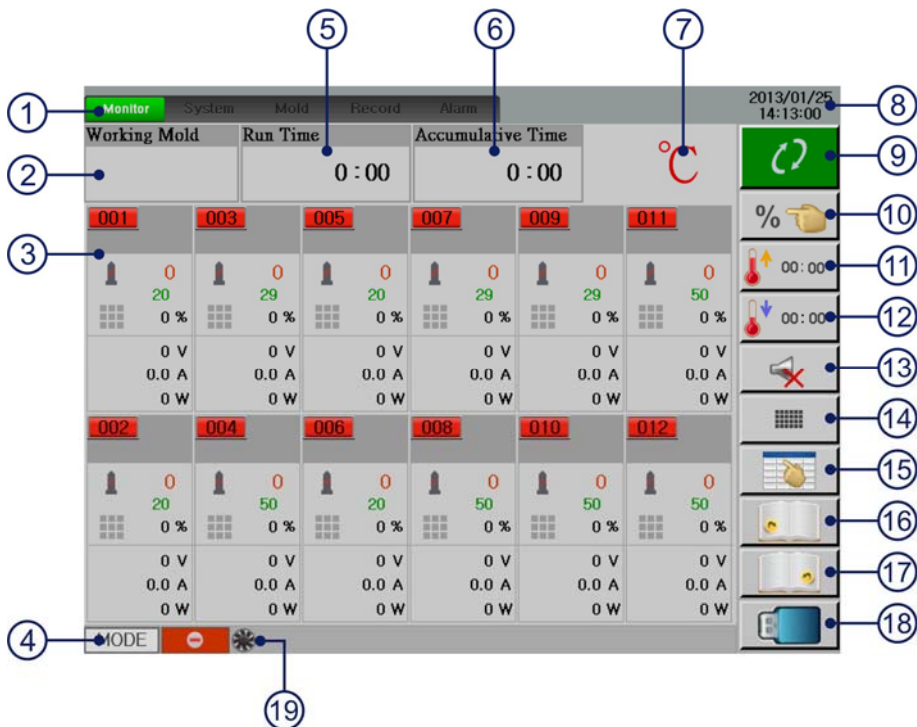

When the basic parameters have been set alright, you can use "Group Setup" to copy parameters to other zones, refer to 6.2-⑧ P36~37 for details.

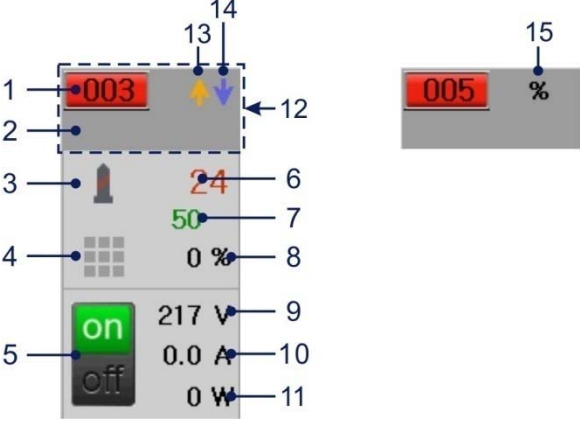
Chapter VI HMI Instructions



6.1 Monitor



























①	Main Menu	Tabs: Monitor, System, Mold, Record, Alarm.
②	Name of Working Mold	Name of current mold (refer to 6.4.2-(1) P45)

<p>③</p>	<p>Zone Status</p>	 <ol style="list-style-type: none"> Zone No.: State is shown by color <ul style="list-style-type: none">  Running  Boost  Manual  Stop  Standby  OFF Zone name Heater type <ul style="list-style-type: none">  Tip  Manifold Output percentage graph Zone switch: ON / OFF Process value (PV) Setting value (SV) <ul style="list-style-type: none"> In Automatic mode, press to set temperature. In Manual mode, press to set output percentage. Zone output percentage Zone voltage
----------	--------------------	---



③	Zone Status	10. Zone current output 11. Zone power output 12. Press the area of zone No. and name to enter parameter setup tab. (refer to 6.2 P29~37 for zone parameter setup) 13. Enable boost 14. Enable standby 15. Enable manual
④	Mode	 Running  Synchronous Cooling  Stopped
⑤	Run Time	Cumulative operating time of the machine for this session.
⑥	Accumulative Time	Total cumulative time that the machine has been used.
⑦	Temperature Unit	The current unit of temperature used by the system: C / °F
⑧	Date and Time	Current date and time (If this is wrong it can be corrected in the System tab.)

⑨	Run / Stop Function	<p>Run: Start control  Go from Stopped   to Running  </p> <p>Stop: Stop control  Go from Running   to Stopped  </p>
		<p>※In the situation of Synchronous Cooling is enabled in System tab:</p> <p>Run: Start control  Go from Stopped   to Running  </p> <p>Synchronous Cooling: Synchronous cooling control  Go from Running   to Synchronous Cooling  </p> <p>Stop: Stop control  Go from Synchronous Cooling   to Stopped  </p>

Select the zone to set to Manual. Selected zones will appear in orange. Press "Confirm" to save to return to Main Menu.

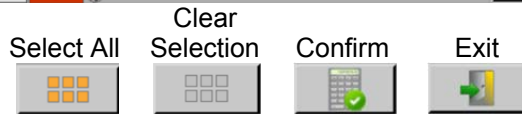
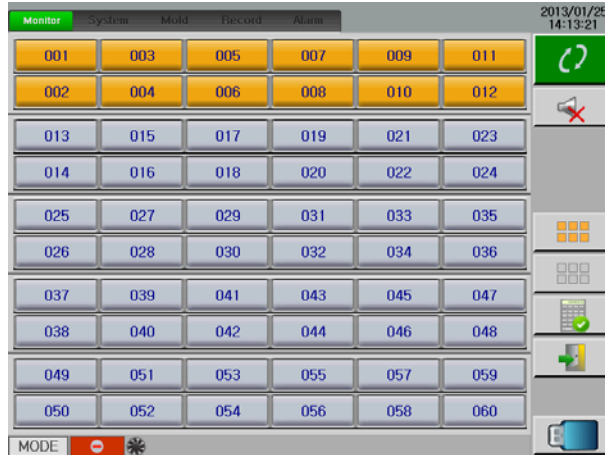

⑩

Manual Switch

Press the zone status area (refer to 6.1-③-12 P21) or Mold setup in Mold tab (refer to 6.2-③-1 P30) to set manual output percentage.

Zones set manual output already will show icon "%" beside zone no., press "Run" to manual output control.



Start heating at the time set by the user. If the temperature reaches the SV during this time (refer to 6.2-③-2 P30), maintain this temperature. If the time expires then turn off this function.

Select zone to heat, set the amount of time to heat the temperature for, then press "Confirm" to save to return to Main Menu.

11

Boost Setup

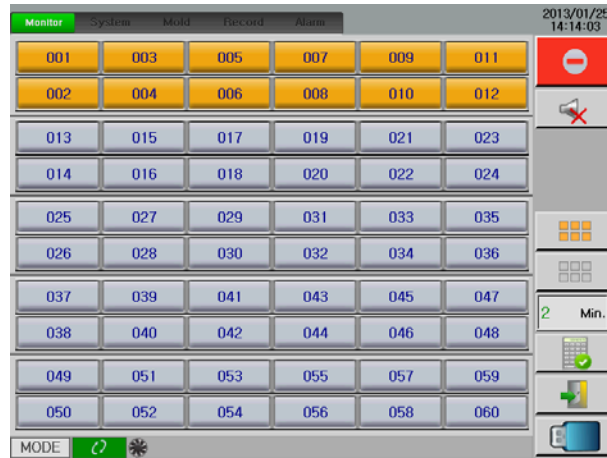

Select All



Clear Selection



Time Setting



Confirm



Exit



Press the zone status area (refer to 6.1-③-12 P21) or Mold setup in Mold tab (refer to 6.2-③-2 P30) to set boost.

Zones set boost already will show icon " ↑ " beside zone no.

11

Boost Setup

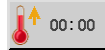

In **MODE** , hold  to turn on/off boost. Color of zone will now change to blue when set.



Start standby temperature control to enter standby temperature mode and maintain the temperature at the set value for the set time (refer to 6.2-③-3 P30). When time is reached, resume original operation. If time expires then automatically turn off this function.

Select zone for standby temperature, set the amount of time to maintain the temperature and then "Confirm" to save to return to Main Menu.

⑫ Standby / Cooling Setup

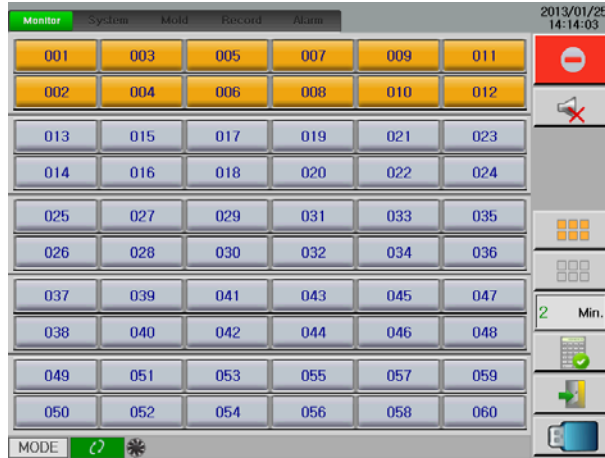





Press the zone status area (refer to 6.1-③-12 P21) or Mold setup in Mold tab (refer to 6.2-③-1 P30) to set standby.
Zones set standby already will show icon "↓" beside zone no.









Standby / Cooling Setup

12



In **MODE** , hold  to turn on/off standby. Color of zone no. will change to blue when be set.



⑬	Audible Alarm Switch	<p>Audible Alarm Switch (This is a button, the graphic is opposite to the status.)</p>  Press to turn on audible alarm.  Press to turn off audible alarm (alarm light will still be displayed).
⑭	Change Page Format	<p>Each press of the button changes the number of zones to display in the Monitor tab.</p> 
⑮	Monitor Page Menu	<p>Choose the range of zones to display from the pop-up menu.</p> 
⑯	Change Monitor Page (Previous Page)	<p>This button appears if the total numbers of zones exceed the maximum number that can be displayed in the Monitor page. Press to change to the previous page.</p> 
⑰	Change Monitor Page (Next Page)	<p>This button appears if the total numbers of zones exceed the maximum number that can be displayed in the Monitor page. Press to change to the next page.</p> 
⑱	Export Current Screen	<p>This button only appears if a USB drive is inserted into the HMI. The current screen is saved as a screenshot to the USB drive. ※USB drive must be in FAT16 or 32 format.</p> 
⑲	Fan Status	<p>The icon will rotate when the fan is running. (TC5200 only)</p> 

6.2 Zone Parameter Setup

Normal Mode

Normal Mode Zone Parameter Setup screen. The interface is divided into several sections:

- 1 Module Setup:** Working Mold ID: 1, No.: 1, Program Version: 1.00, Name: SAMPLE
- 2 General:** PV. Offset: 0, TC. Type: J/K, Heater Type: TIP/M.F., Soft Start Disable: on/off, Self Tune: Every, PB.: 0, IT.: 0, DT.: 0
- 3 Control:** Manual %: 0, Boost Temp: 20, Standby Temp: 100, Slave Zone: 2, Output Limit: 100, Temperature Limit: 300, Loop Err. Behavior: Slave, Output Mode: Z.C. P.A.
- 4 Alarm:** Low Limit: on/off, Low Alarm Range: 20, Standby: on/off, High Limit: on/off, High Alarm Range: 20, Standby: on/off, Absolute Alarm: on/off, ABS. Alarm Range: 0, Current Detect: on/off
- 5 Status:** Process Value: 25, Setting Value: 25, Zone Switch: on/off, Control Mode: Auto Man., Alarm Message, Abnormal Message, Room Temp: 25, HT Sink Temp: 25, Frequency: 60

Simple Mode



Simple Mode Zone Parameter Setup screen. The interface is simplified compared to Normal Mode:

- 1 Module Setup:** Working Mold ID: 1, No.: 1, Program Version: 1.00, Name: SAMPLE
- 2 General:** PV. Offset: 0, Soft Start Disable: on/off
- 3 Control:** Output Mode: Z.C. P.A.
- 4 Alarm:** Low Alarm Range: 20, High Limit: on/off, High Alarm Range: 20, Current Detect: on/off
- 5 Status:** Process Value: 25, Setting Value: 25, Zone Switch: on/off, Control Mode: Auto Man., Alarm Message, Abnormal Message, Room Temp: 25, HT Sink Temp: 25, Frequency: 60

①	Module Setup	<ol style="list-style-type: none"> 1. Name of working mold (refer to 6.4.2-(1) P45) 2. Module program version 3. ID: The communications ID for the current zone. (automatically assigned by system) 4. Zone: Number of current zone 5. Name: Name of current zone. This can be defined by the user. 6. Process Value: The actual temperature of the current zone (PV). 7. Setting Value: The setting value (SV) for the current zone. Press to set. 8. Zone Switch: Choose to use the current zone or not. 9. Control Mode: Auto or Manual.
②	General Parameter Setup	<ol style="list-style-type: none"> 1. PV. Offset: Set the PV offset for that zone. 2. TC Type: J/K type thermocouple. 3. Heater Type: TIP / M.F. (Manifold) 4. Soft Start: Enable heater drying function. 5. Self Tune: Enable Self-tuning mode (No / Once / Always) 6. Proportion Band: The output proportion band 7. Integral Time: Integral time 8. Differential Time: Differential time
③	Control Parameter Setup	<ol style="list-style-type: none"> 1. Manual Output %: Set the manual output percentage. 2. Boost Temp: Set the boost temperature. 3. Standby / Cooling Temperature: Set standby / cooling temperature. 4. Slave Zone: Set the zone to slave the current zone if thermocouple fails. 5. Output Limit: 0~100%. The maximum output percentage for that zone. 6. Temperature Limit: The maximum set temperature for that zone. 7. Output Mode: Z.C. (Zero cross) / P.A. (Phase angle)



<p>③</p>	<p>Control Parameter Setup</p>	<p>8. Loop Err. Behavior: Stop / Manual / Slave Stop: Stop output in the event of thermocouple break. Manual: Automatically switch temperature control for that zone to Manual mode after thermocouple break. Follow the manual output percentage so the heater maintains the production temperature and keeps production running. ※The manual output percentage must be set in Control Parameters. Slave: Follow the output percentage of the zone slaved to after thermocouple break. This enables more precise temperature control for the current zone and keeps production running. ※The zone to slave to must be set in advance in Control Parameters.</p>
<p>④</p>	<p>Alarm Parameter Setup</p>	<p>1. Low Limit: The alarm logic when PV is lower than the "SV - Low Alarm Range". 2. Low Alarm Range: Press on number to set. 3. Low Standby: When control is started or SV is changed, do not trigger alarm the first time that PV is lower than "SV - Low Alarm Range". 4. High Limit: The alarm logic when PV is higher than the "SV + High Alarm Range". 5. High Alarm Range: Press on number to set. 6. High Standby: When control is started or SV is changed, do not trigger alarm the first time that PV is higher than "SV + High Alarm Range". 7. Absolute Alarm: The alarm logic for that zone when PV is higher than "ABS. Alarm Range". 8. ABS. Alarm Range: Press on number to set. 9. Current Detect: Disable logic for current detection. Temporarily disable the current alarm when the current sensor has failed.</p>

⑤	Module Status	<p>1. Alarm Message: The abnormal temperature alarm message for that zone.</p> <ul style="list-style-type: none"> ● Lower limit alarm ● Absolute alarm ● Higher limit alarm <p>2. Abnormal Message: Abnormal message for that zone.</p> <ul style="list-style-type: none"> ● Thermocouple break ● Thermocouple reversed ● Thermocouple short ● Heater overload or short ● TRIAC short or heater ground anomaly ● Control loop break ● Memory read / write error ● Abnormal temperature increase ● Fuse Open Circuit <p>3. Room Temp: Ambient temperature of control module.</p> <p>4. Heat Sink Temp.: Temperature of control module's heat sink. This is used for automatically triggering the heat sink fan.</p> <p>5. Power supply frequency</p>
⑥	Confirm settings	
⑦	Cancel settings	

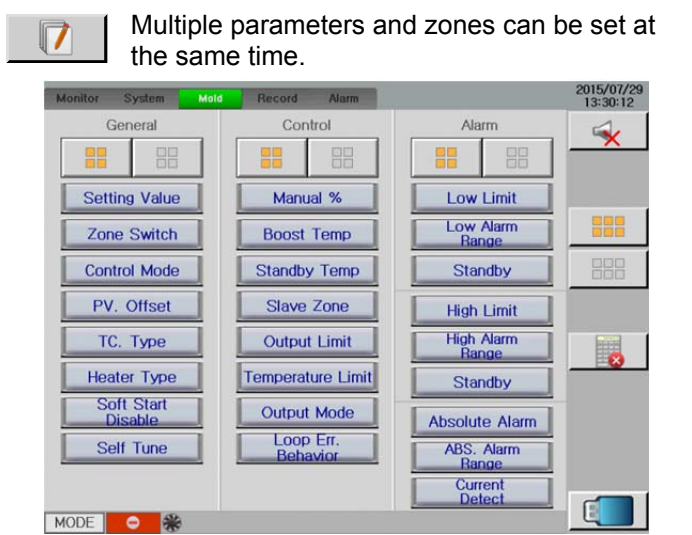

Multiple parameters and zones can be set at the same time.

8

Group Setup

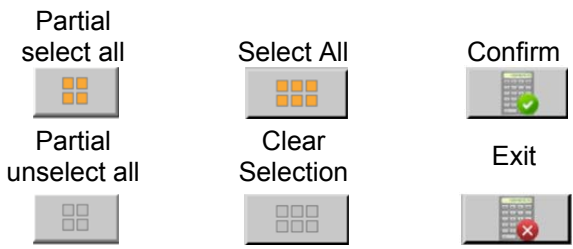

Enter the select parameters for group setup. Alternatively, use the "Partial select all" and "Partial unselect all" functions to quickly select individual items in each category. The "Select all" and "Clear Selection" functions at the very right can also be used to quickly select all items. "Confirm" to enter zone selection. (The base of setting: The set value base on module set value when you page to group setting page.)

Select the zones for group setup.

8

Group Setup

Monitor						System						Hold						Record						Alarm											
001						003						005						007						009						011					
002						004						006						008						010						012					
013						015						017						019						021						023					
014						016						018						020						022						024					
025						027						029						031						033						035					
026						028						030						032						034						036					
037						039						041						043						045						047					
038						040						042						044						046						048					
049						051						053						055						057						059					
050						052						054						056						058						060					

MODE
⏮
⏭

Select All



Clear Selection



Confirm



Exit



"Confirm" to complete group setup.

6.3 System Setup





1. General Parameters

- (1) Date-Time: Press to bring up setup screen. Once setup is complete, press "Save & Exit".
- (2) Language: Default English.
- (3) Brightness: Adjust the screen brightness.
- (4) Temperature Unit: Switch between Celsius (°C) and Fahrenheit (°F).

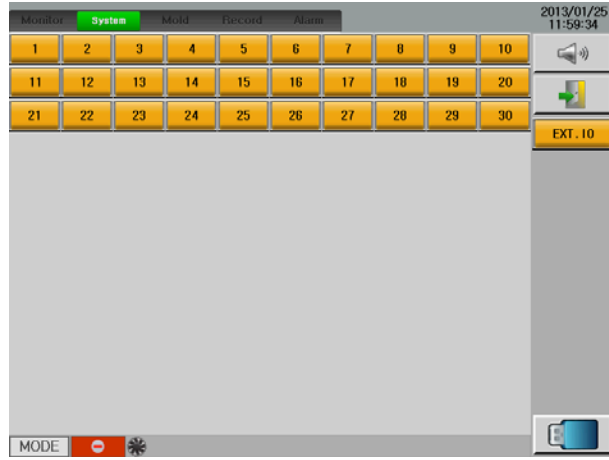
- (5) Login: Input a password to enter the corresponding management level.
 - (6) Logout: Logout and return to the default Level 0.
 - (7) Password Management: Change the password for each level (cannot change the password of higher level than login).
2. Advanced Parameters 1
- (1) Fan: Set fan to auto / start.*
 - (2) Turn Synchronous Cooling on or off.
 - (3) Select Synchronous Heating ON / Synchronous Heating OFF / Timing Warming
 - (4) Re-Connect: Re-connect to the module.
 - (5) Program Update (Button only appears when USB thumb drive is inserted):
 - Select the path of the file to read then press "Confirm" to change to that path.
 - <C:> HMI local disk
 - <E:> USB drive
 - Select the file to update then press "Confirm" to begin.
 - When the PRP file has been read, remove the USB drive. Once the process is complete, the system will return to the welcome screen. Please **turn off the power and restart the TC1200 / TC2400 / TC3600.**
3. Advanced Parameters 2
- (1) Clear Accumulated. Time.
 - (2) ID ON/OFF: Turn off unused or problematic IDs.



- When ID is shown as  the controller is connected to the HMI.
- When ID is shown as  the controller is not connected to the HMI.

6.4 Mold Maintenance

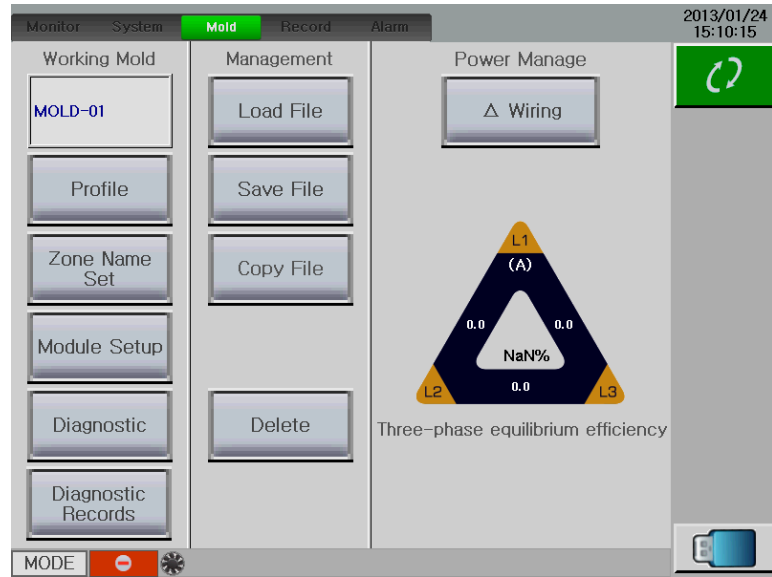

1. Working Mold.

- (1) Name of working mold (refer to 6.4.2-(1) P45)

(2) Zone Preview: Display the status of each zone

Mold Profile													2015/07/29 13:30:45		
ZONE	SW	PV	SV	OUT (%)	TC TYPE	HT TYPE	Output Mode	ALL	ALH	AMP	VOL	WATT	ERR CODE		
001	ON	25	25	0	K	Tip	ZC.	20	20	0.0	220	0	---		
002	ON	25	25	0	K	Tip	ZC.	20	20	0.0	220	0	---		
003	ON	25	25	0	K	Tip	ZC.	20	20	0.0	220	0	---		
004	ON	25	25	0	K	Tip	ZC.	20	20	0.0	220	0	---		
005	ON	25	25	0	K	Tip	ZC.	20	20	0.0	220	0	---		
006	ON	25	25	0	K	Tip	ZC.	20	20	0.0	220	0	---		
007	ON	25	25	0	K	Tip	ZC.	20	20	0.0	220	0	---		
008	ON	25	25	0	K	Tip	ZC.	20	20	0.0	220	0	---		
009	ON	25	25	0	K	Tip	ZC.	20	20	0.0	220	0	---		
010	ON	25	25	0	K	Tip	ZC.	20	20	0.0	220	0	---		

Page Menu



Previous Page



Next Page



- ZONE: Zone No.
- SW: Zone switch
- PV: Process value
- SV: Setting value
- OUT: Output percentage
- TC TYPE: Thermocouple type
- HT TYPE: Heater type
- Output Mode
- ALL: Range of lower limit
- ALH: Range of higher limit
- AMP: Amperage
- VOL: Voltage
- WATT: Power rating
- ERR CODE: Error code

(3) Zone Name Setup

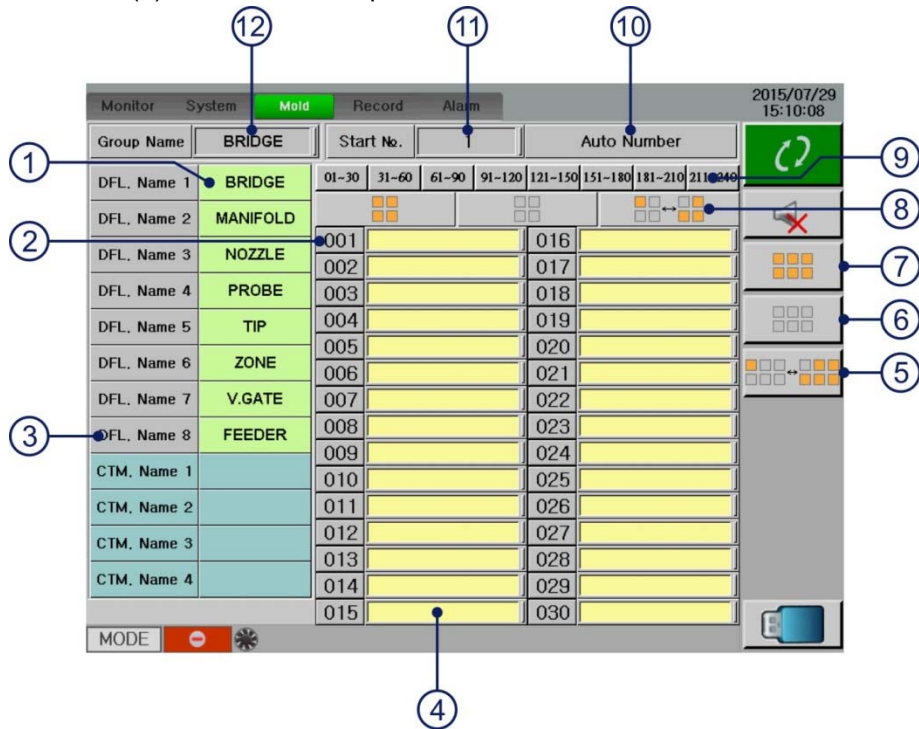

- | | |
|---|---|
| ① Default name
(Set by system. Can't be changed) | ⑦ Select All |
| ② Zone (Multiple selection) | ⑧ Invert selection
(on displayed zone tab) |
| ③ Custom name | ⑨ Zone tab |
| ④ Zone name | ⑩ Automatic No. |
| ⑤ Invert selection
(for all zones) | ⑪ Starting No. |
| ⑥ Clear Selection | ⑫ Group name editing area |



- ① The custom name file saved:
 - Select "Group ID" editing area, enter the custom name then press "Custom Name 1~5" in lower left, then the pop-up window show out, press "Confirm" to save custom name.
 - ② Automatic ID setup:
 - Select the area expect to set, you can select all (for all zones, displayed zone tab), or manual select (multi-selectable).
 - Select the default name to apply from the left, enter starting number then press "Automatic ID". Then the pop-up windows press "Confirm" to begin setup.
 - ③ Manual setup:
 - Select any zone name to set; also you can modify its name.
 - * In this mode, multiple selections have no effect. Only the selected zones are changed.
- (4) Module Setup
- Select to enter the zone selection tab. select the zone to setup to enter the zone setup tab.
- (Refer to 6.2 P29~37)

(5) Self-Diagnostic: Check the thermocouple, heater and connection for each zone to make sure they are working properly.

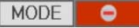
*Self-diagnosis can only be used in Stop  mode.



Previous Page



Select All



Diagnostics Page



Next Page



Clear Selection



Exit



Select the zone to diagnose then press  to enter Diagnostics page.



Zone	001 Normal 001 Alarm 002 Analyzing 003 Pending 007 Not selected
<div style="border: 1px solid gray; padding: 2px; width: fit-content;">Start Temp. 50</div>	Temperature Control start: Press to set value (The unit setting is the present system setting). If the temperature in any zone is higher than the starting temperature then the next zone will be diagnosed first. When the remaining zones have been diagnosed, the system will return to the original zone and re-check the temperature is lower than start setting or not? If it lower than the setting, then diagnose it.
<div style="border: 1px solid gray; padding: 2px; width: fit-content;">Rise Temp. 50</div>	Rise up temperature: Press to set value (Using the current system unit). The amount of temperature to rise during diagnosis.
<div style="border: 1px solid gray; padding: 2px; width: fit-content;">Delay Time 10</div>	Delay time: Press to set value (Unit is seconds). The action interval between zones.
<div style="border: 1px solid gray; padding: 2px; width: fit-content; text-align: center;">▶</div>	Start: Begin self-diagnosis.
<div style="border: 1px solid gray; padding: 2px; width: fit-content; text-align: center;">⏸</div>	Pause: Finish diagnosing the current zone then suspend the diagnosis function. Press "Start" to resume.
<div style="border: 1px solid gray; padding: 2px; width: fit-content; text-align: center;">⏹</div>	Stop: Immediately stop the diagnosis of all zones.

(6) Diagnosis record

Monitor	System	Mold	Record	Alarm							2015/07/14 19:10:34
Diagnostic Record											
ZONE	AMP	VOL	OHM	WATT	TC	HT	FUSE	TRIAC	WIRE 1	WIRE 2	
001	0.0	0	0	0	OK	OK	OK	OK	0	0	
002	0.0	0	0	0	OK	OK	OK	OK	0	0	
003	0.0	0	0	0	OK	OK	OK	OK	0	0	
004	0.0	0	0	0	OK	OK	OK	OK	0	0	
005	0.0	0	0	0	OK	OK	OK	OK	0	0	
006	0.0	0	0	0	OK	OK	OK	OK	0	0	
007	0.0	0	0	0	OK	OK	OK	OK	0	0	
008	0.0	0	0	0	OK	OK	OK	OK	0	0	
009	0.0	0	0	0	OK	OK	OK	OK	0	0	
010	0.0	0	0	0	OK	OK	OK	OK	0	0	

MODE  

Previous Page



Next Page



Tab Menu

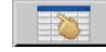

- ZONE: Zone No.
- AMP: Heater amperage
- VOL: Heater voltage
- OHM: Heater resistance
- WATT: Heater power rating
- TC: Thermocouple status
- HT: Heater status
- FUSE: Fuse status
- TRIAC status
- WIRE 1: Wiring error 1
- WIRE 2: Wiring error 2

2. Memory Management



(1) Load File

- Select path of the file to load, then press "Open Folder" to switch to the path.

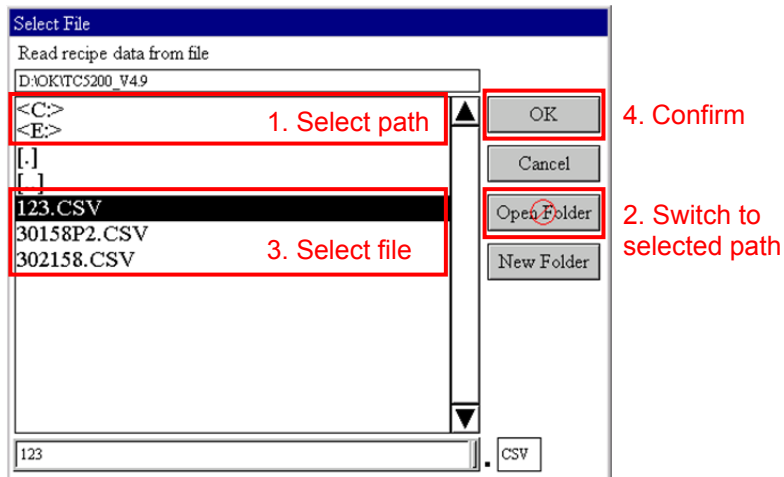

<C:> HMI local disk

<E:> USB drive

- Select the required file, then press "OK" to load the stored parameters into the HMI and write them to the mold's zone parameters.

※Here the file name is the name of the working mold.

(2) Save File

- Select the path of the file to store, then press "OK" to switch to the path.
- Select the name-editing block (blank area) at the bottom of the window. After renaming it, press "Ent" and then "OK" to save.
- Or just select the original file, then press "OK" to overwrite.

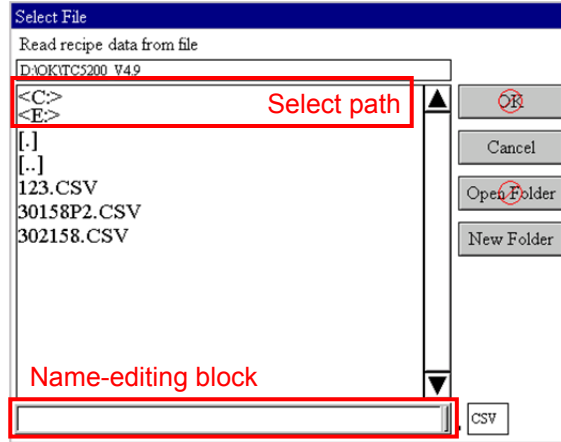

(3) Copy File [used with "Select Path" (* previous version called "Copy Path")]

- Select the path of the file to copy, then press "OK" to switch to the path.
- Select the file to copy, then press "OK".
- Continue onto " Select Path " in the following section.

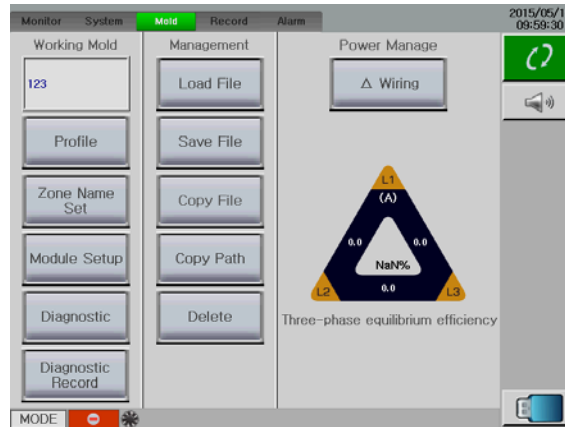

- Select a path to paste the copied file, then press "OK" to switch to the path.
- Select the name-editing block (blank area) at the bottom of the window. After renaming it, press "Ent" and then "OK" to save.

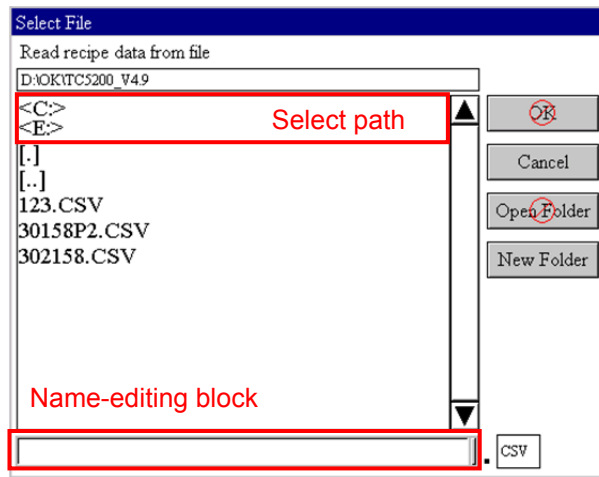

(4) Delete

- Select the path of the file to delete, then press "OK" to switch to that path.
- Select the file to delete, then press "OK".

3. Power management

Δ Wiring

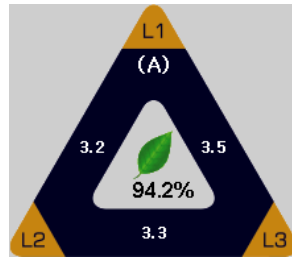

Y Wiring

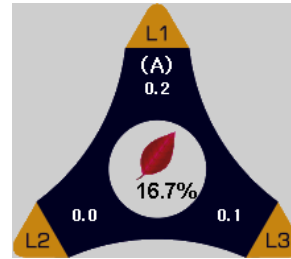

Tri-phase balance efficiency is calculated using the loads of each phase in the electrical system. The user can use the tri-phase balance efficiency to adjust the heater configuration. Tri-phase balance reduces power loss.

 90~100%	 80~89%	 70~79%	 70% ↓
---	--	--	---

6.5 Curve Record

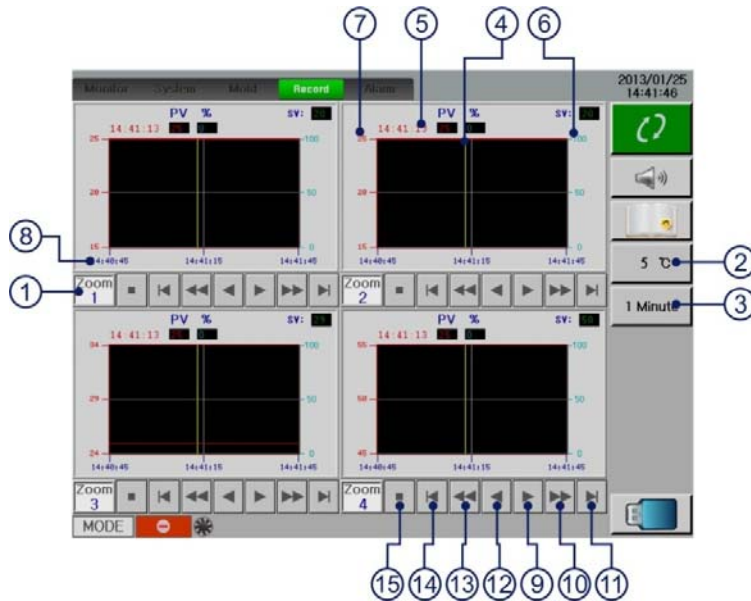

- ① Display Zone: Select to set the zone to inspect.
- ② Temperature Interval: Select to cycle through the temperature display intervals.
(5°C→10°C→20°C→50°C→100°C→200°C→5°C)
- ③ Time Interval: Select to cycle through the time display intervals.
(1 min → 10 min → 30 min → 1 hour → 2 hours → 3 hours → 4 hours → 1 min)
- ④ Extract line: Press on any part of the graph to display the yellow extract line. Drag to the time to inspect.
- ⑤ Display extracts line position and time.
- ⑥ Output %
- ⑦ Temperature axis: Value changes according to the current temperature interval.
- ⑧ Time axis: Value changes according to the current time interval.
- ⑨ Time axis control: Forward
- ⑩ Time axis control: Forward (Large)
- ⑪ Time axis control: Move to front
- ⑫ Time axis control: Reverse
- ⑬ Time axis control: Reverse (Large)
- ⑭ Time axis control: Move to rear
- ⑮ Time axis control - Pause: Press to pause time axis and the icon turns hollow. Press again to return to normal.

6.6 Press Alarm Communication Setup

TC1200/TC3600 External Alarm Input control from the press

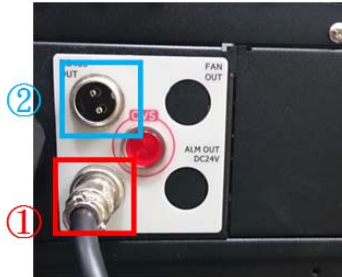

1 External signal connection Socket. For press alarm

2 Multi units communication socket. (Ex. TC1200w/HMI + TC1200w/o HMI)

This Picture below shows 1 end of the cable supplied. This end connects to the press for external alarm

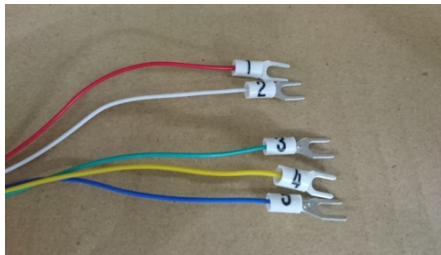

There are five color wires, Red wire (No.1) is the signal line DI1, White (No.2) for the signal line DI2, Green wire (No.3) is the ground wire. The Yellow Wire (No.4) and the Blue wire (No.5) are the signal lines DO1

Please note: The external control signal is 24V.

Once the wiring to the press is complete, turn the controller on.

Login Password → Enter 1111 for basic, Enter 2222 for Middle, Enter 3333 for Management



6.6 Press Alarm Communication Setup

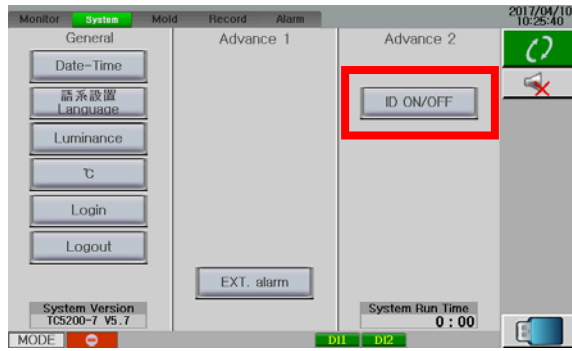

Click on the ID ON/OFF button, the following screen will, make sure EXT.IO is open (red box below)

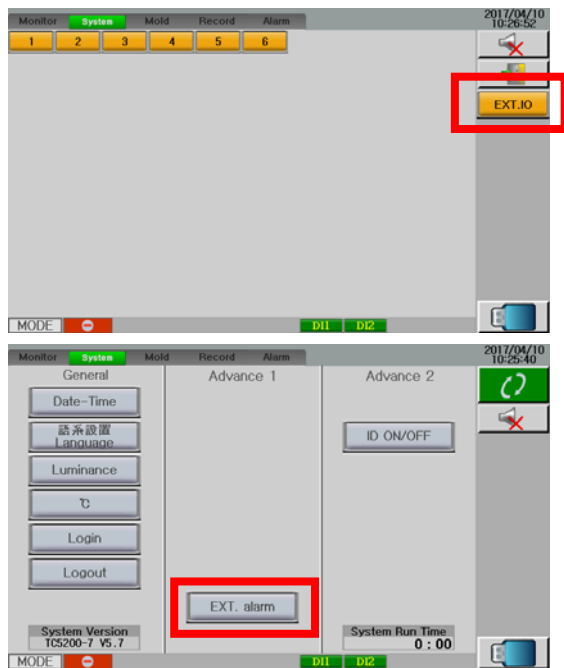

Click on the "Ext. alarm", the following will appear.

DI1 and DI2 each have three options. / Set to "Shut down heats", "Standby on", or "No action"

“Shut down heats”→ Turn off output, while there is signal.

“Standby on”→ Cool down standby, while there is signal.

“No action”→ No action while there is signal, as turn off the function.

DO1 has two options, / set to “close” or “open”

“Close”→When HMI provide alarm signal, no any action (as turning off this function)

“Open”→When HMI provide alarm signal (Except for communication alarm), yellow (No.4) and blue (No.5 coil) wires will be shorted.

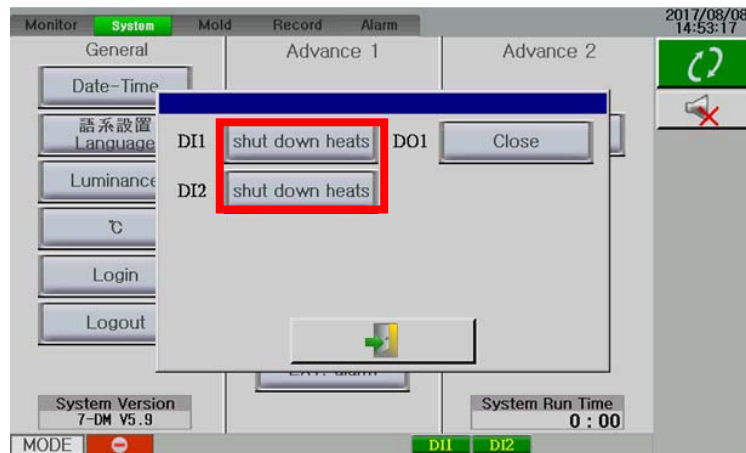

Example, DI1 is set to "shut down he heats", DI2 is set to "standby on"

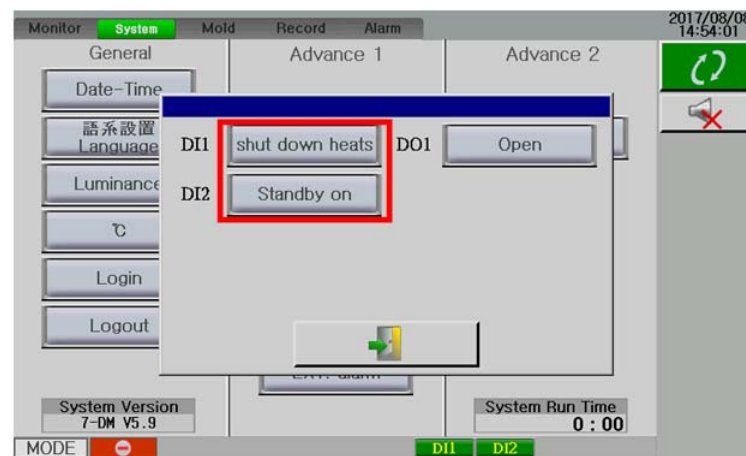

In the red box below, (DI1, DI2), to determine whether the external signal on/off, red is ON and green is OFF

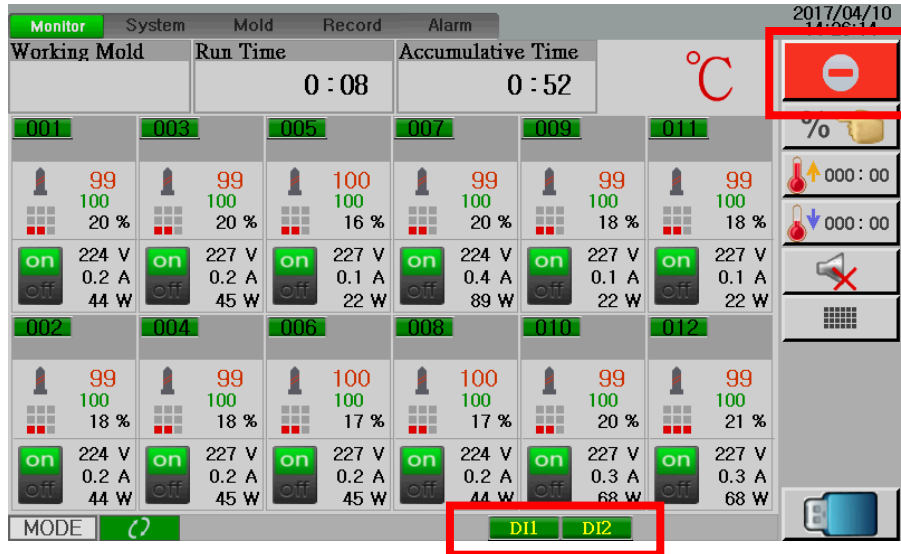

DI1 ON as shown below, DI1 red (input) to shut down heats, the upper right of the start button has been stopped

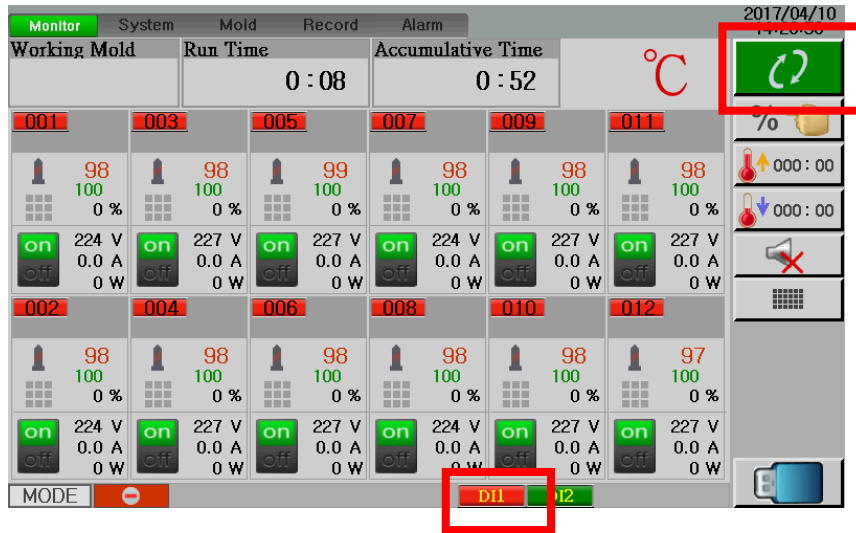

DI2 ON as shown below, DI2 red (input) to “Standby on”, all module number part has been blue to do cooling action

(Note: The falling temperature will be set according to the module Standby TP. The settings are different, this example is 1-6 Standby TP.=10°/7-12 Standby TP.=30°)

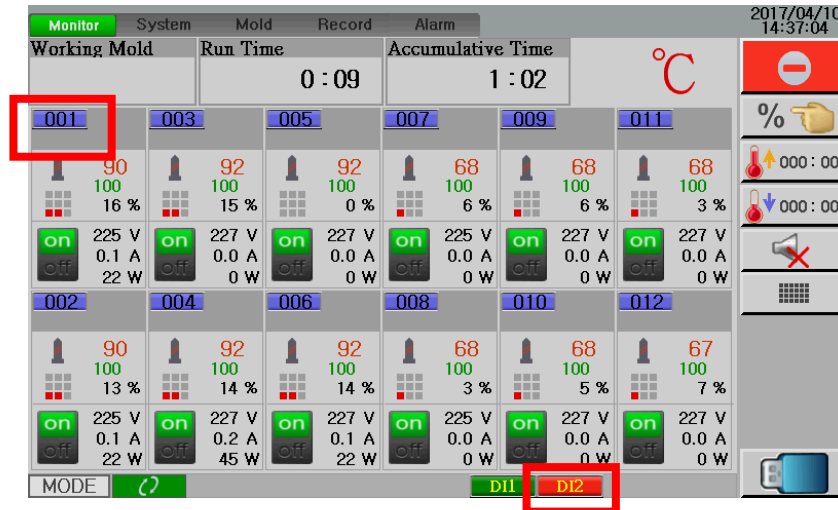

Please Note: If DI1 and DI2 both ON (red), the first action is shut down heats, the second action is standby on the last is the no action.

This picture below shows the controller end of the cable supplied

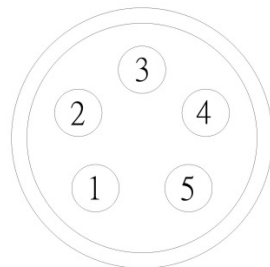

According to the circular connector number
 PIN 1--- J24 PIN 1 - IN 1 (red)
 PIN 2--- J24 PIN 2 - IN 2 (white)
 PIN 3--- J24 PIN G - ING (green)
 PIN 4---J29 PIN 1 (yellow)
 PIN 5---J29 PIN2 (blue)

6.6 Alarm Record

Date	Time	Status	Message
2013/01/25	14:41:00	C	ID 30 Communication Error
2013/01/25	14:39:55	A	ID 30 Communication Error
2013/01/25	14:32:04	A	ID 32 Communication Error
2013/01/25	14:32:03	A	ID 31 Communication Error
2013/01/25	13:46:17	A	ID 24 Communication Error
2013/01/25	13:46:16	A	ID 23 Communication Error
2013/01/25	13:46:16	A	ID 22 Communication Error
2013/01/25	13:46:15	A	ID 21 Communication Error
2013/01/25	13:46:15	A	ID 20 Communication Error
2013/01/25	13:46:14	A	ID 19 Communication Error
2013/01/25	13:46:14	A	ID 18 Communication Error
2013/01/25	13:46:14	A	ID 17 Communication Error
2013/01/25	13:46:13	A	ID 16 Communication Error
2013/01/25	13:46:13	A	ID 15 Communication Error
2013/01/25	13:46:12	A	ID 14 Communication Error
2013/01/25	13:46:12	A	ID 13 Communication Error
2013/01/25	13:46:11	A	ID 12 Communication Error
2013/01/25	13:46:11	A	ID 11 Communication Error
2013/01/25	13:46:11	A	ID 10 Communication Error
2013/01/25	13:46:10	A	ID 9 Communication Error

- ① Date: Select column title to sort by date.
- ② Time: Select column title to sort by time.
- ③ Status: Active (Red), Stop (Green); press on column titles to sort by status.
- ④ Message: Content of alarm message.
- ⑤ Clear alarm log.

Chapter VII

Troubleshooting

Problem	Check
Nothing happens after turning on power	<ul style="list-style-type: none"> ● Is main power on? ● Check power cable (wiring) are connected properly.
No communications	<ul style="list-style-type: none"> ● Is control module loose? ● Is control module broken? ● Start connection reset.
Unstable temperature control	<ul style="list-style-type: none"> ● Refer to 6.2-②-5 P30, set Self Tune to "Always".
TC Break / Reversed Alarm	<ul style="list-style-type: none"> ● Follow alarm inspection checklist.
Thermocouple Short Alarm	<ul style="list-style-type: none"> ● Are TC lines properly placed? ● Is there a short circuit in TC line?
Heater Alarm	<ul style="list-style-type: none"> ● Follow alarm inspection checklist.
Control Circuit Alarm	<ul style="list-style-type: none"> ● Is heater line open? ● Is wiring loose? ● Is control module broken?
TRIAC Short Alarm	<ul style="list-style-type: none"> ● Change control module.
Abnormal Temperature Increase Alarm	<ul style="list-style-type: none"> ● Are heaters properly placed? ● Are TC lines properly placed?
Circuit Breaker Alarm	<ul style="list-style-type: none"> ● Change fuse for that zone.

Chapter VIII Connector Wiring

8.1 Connection type A

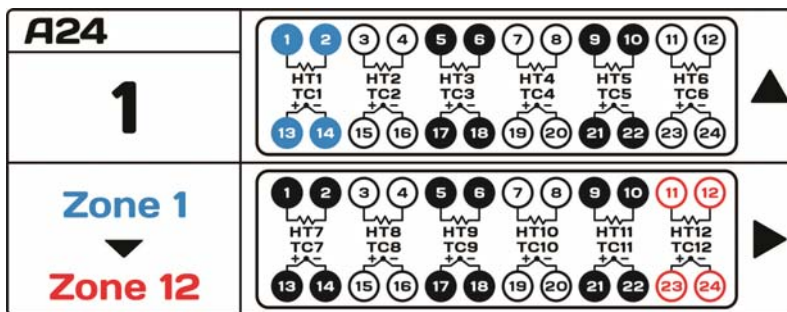

8.2 Connection type B

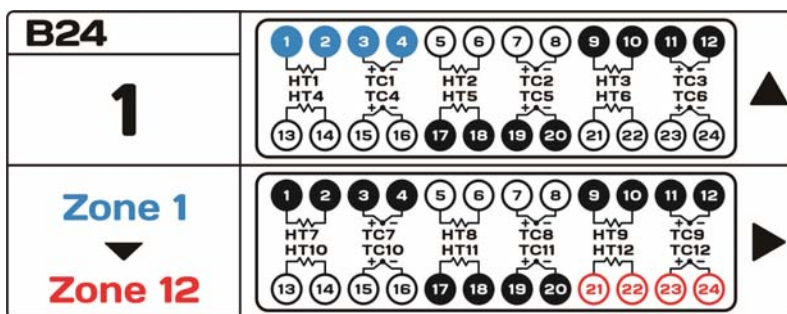

8.3 Connection type C

